

# **GMC** **SPEED MANUAL**

**HOW TO HOP UP 270 & 302 GMC'S**  
**HOW TO INSTALL GMC'S IN CHEVROLETS**  
**HOW TO CHOOSE THE PROPER EQUIPMENT**

★ **MODIFICATION**

★ **ASSEMBLY**

★ **TUNING**

★ **CAMSHAFTS**

★ **CARBURETION**

★ **COMPRESSION**

★ **IGNITION**

★ **EXHAUST**

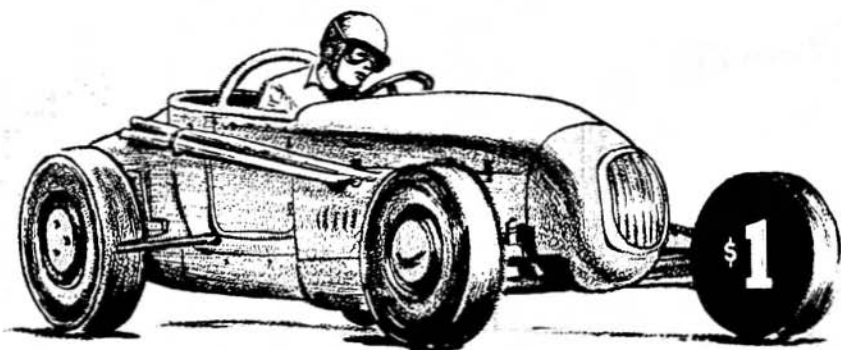

**CALIFORNIA BILL FISHER**

COPYRIGHTED

February 1, 1955

by the author and publisher

**FRED W. FISHER**

Permission to reproduce any portion of  
this manual must be obtained before use

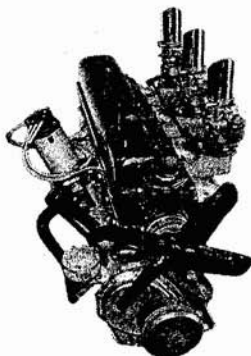

GMC engines are rapid, rugged, and reliable. Providing more horsepower per dollar than any other single engine, they adapt easily to Chevrolet and Ford chassis for fast-road or all-out-competition use.

## THE FABULOUS GMC

About 1948, several speed enthusiasts began "eye-balling" the 270 GMC engine with the idea of installing it in their Chevrolets. Tape measures soon showed that the well-built engine was a mere 1.5" longer than a Chevrolet and only slightly heavier. Many Chevy parts, including bell housing and fly-wheel, matched perfectly. It was a simple matter to fabricate motor mounts and move the radiator forward to clear. The first installation took less time than could have been imagined, and "Jimolet" owners were off to the races.

While the first GMC enthusiasts had to fabricate their speed equipment, it wasn't long until high quality conversion parts became available. The biggest single boost given the GMC movement was the development of the VENOLIA pistons by Wayne F. Horning, a design since sold to Frank McGurk and copied widely by other piston manufacturers. Once larger and lighter-than-stock pistons became available, the full potentialities of the GMC engines began to be realized.

GMC gave its engines another shot in the arm by announcing first the 270H cylinder head, which had over 50% more port area than previous models; and then really overjoyed six-in-a-row lovers by producing the 302 engine which could easily be opened up to provide 320 cubic inches—a welcome sight for the sore eyes of Chevrolet owners who had long been pinned down to a paltry 248 cubes—if they were lucky enough to have a Hi-Torque.

Many fellows, after investigating the high initial and construction costs of the OHV-8's, have realized that *the GMC provides the most horsepower for the least dollar expenditure*, a very happy situation. Fine as the late V-8's are, they are both heavy and expensive to build. Furthermore, they can't cope with the lightweight GMC's low-speed torque, especially when it is providing the motive effort for a light Chevrolet or Ford.

So—if you are a Chevrolet fan who has been moaning about getting shut off by the new cars and big V-8's, put away your crying towel and build yourself a GMC. Its hairy-chested horses will outperform any of the late-model Cads, Olds, Buicks, Lincolns, or Chrysler products. What could be more fun than that—automotively speaking?

## HOW TO OBTAIN A GMC

The simple, easy, expensive way is to buy a new one from your dealer. You can usually obtain used ones by taking time enough to look around. General Motors pays each of its dealers \$15 to break up used short blocks which are traded in on new equipment. Many dealers can be persuaded to part with these blocks for a bit more cash, especially when you let them know that they will be selling you the necessary stock parts to complete the engine.

If all of the dealers in your area "stand pat" with factory policy, make friends with the agency's mechanics and parts men. The effort involved in being diplomatic will save you lots of that *long green stuff with the short future*. These men will often be able to tell you of a trucker who is planning to replace his present engine with a new short block or complete engine. Contact the trucker and offer him five or ten dollars more than the agency will give him for the "core," in return for clear title to his engine. After all, it will be much better off in your car than lying broken and rusty in some junk yard. Be sure to secure all of the necessary papers for his signature, and let him know that you'll be glad to pick up the engine from the agency when it is removed.

A GMC engine and its displacement are identified by a plate on the left of the block at the rear, just above the gasket flange. It specifies bore, stroke, and engine serial number. The serial number is also repeated on the right side of the block on a ledge just aft of the distributor, as on Chevrolets. The first three serial-number digits are the GMC model. For example, a 270 block will have a serial number beginning 270, with the rest of the number following. Five small freeze plugs on the left side of GMC blocks distinguish them from Chevrolets, which have only two.

Don't bother to purchase or attempt to modify a GMC smaller than a 270. Get at least a 270 or a 302, unless you are buying a short block for the specific purpose of obtaining a short-stroke crank from one of the small-displacement jobs.

While the small GMC's (228, 236, 248, and 256) would seem ideal for racing in classes where displacement is limited, it is usually better to use a Chevrolet. The reason: lightweight, racing pistons are only available for bore sizes 3-25/32" and larger.

**NOTE:** A short block consists of a cylinder block, crankshaft, connecting rods, pistons, wrist pins, camshaft and timing gears, and a front motor-mount plate. Other items, such as oil pumps, are occasionally left on the short block. Complete engines are usually better buys for those persons building road jobs.

Check with your State Department of Motor Vehicles to find out just what is necessary when making an engine transfer. Don't mention that you are building a hotrod, just indicate that you are buying a used engine to install in your present automobile. You will need to know what papers will be required to prove that clear title to the engine has been obtained.

When you buy a new GMC block, the problem is somewhat simplified, but at greater initial expense. Even a new engine will require your checking with the state laws to determine whether a new number is to be assigned or the number transferred from your Chevrolet block.

## BE HONEST WITH YOURSELF . . . & SAVE MONEY!

One problem constantly arises when discussing engine modifications. Most persons refuse to be honest with themselves as to what performance they really want. This causes a lot of difficulty and misunderstanding, as well as the unnecessary expenditure of large amounts of hard-earned money. *Before you build or buy a single part for your GMC, decide just what you want that engine to do!* If it must compete with other all-out engines, then recognize that fact and purchase the necessary parts to achieve that type of performance. But, be prepared to spend large sums of money for both maintenance and fuel. If your wife occasionally drives the car, or you must use it as daily drive-to-work transportation, be satisfied with a smoother-running, less radically modified engine which will cost you less money to build and operate.

A fellow purchased an engine from us, specifying that it was to be driven for pleasure on the streets and highways. We installed a "Road-Type GMC" engine in his car equipped as follows:

248 GMC crankshaft with 3-13/16" stock stroke, 270 block, 8.5:1 3-15/16" pistons, knurled to remove half the clearance, early GMC head with large valves, heavy single valve springs, stock GMC exhaust manifold, and dual manifold with exhaust heat. 3.55:1 rear-end gears were installed with the other equipment, as was a needle-bearing cluster gear in the transmission.

The first week he had the engine, he went to the drag races. The car ran quietly with no trace of fuss or bother and turned a respectable 82 mph in the quarter mile, or about as fast as the average Olds 88 or Jaguar XK-120 roadster. This was Sunday.

Monday morning he got up early to start complaining . . . other GMC's had been faster. This was true, for a '50 Chevy coupe had turned 95 that day for a new record. We tried to explain that this other car was not suitable or reliable enough for the type of driving which he intended to do, and that the other engine had been assembled, together with a Ford transmission, at far greater expense than the customer had indicated he was willing to pay.

He then informed us that his other car would have to do for the street—that this new GMC had to go out and get RECORDS! Since that time the car has been modified as follows:

4.11:1 gears, super cam, three-carb manifold without heat, headers and dual exhausts, 270H head with large exhaust valves, dual valve springs and competition retainers, 4" stroke 270 crankshaft, and other modifications too numerous to list here.

Almost the original cost of the engine was expended needlessly. This could have been avoided had the man faced facts before ordering a mildly converted road-type engine.

So — buy everything with the final picture in mind. If you use your car for transportation, but still want all-out performance, keep a spare stand-by engine to use if the GMC "coughs its cookies." Or — keep the modifications within the limits which we will describe for an economical and reliable road job. An all-out GMC will not be more prone to blow-up than any other engine. In fact, they are more reliable than Ford V-8 or Merc (flatheads) engines. BUT, blow-ups happen when racing even the most expensive engines. Witness those which fall by the wayside each year at Indianapolis!

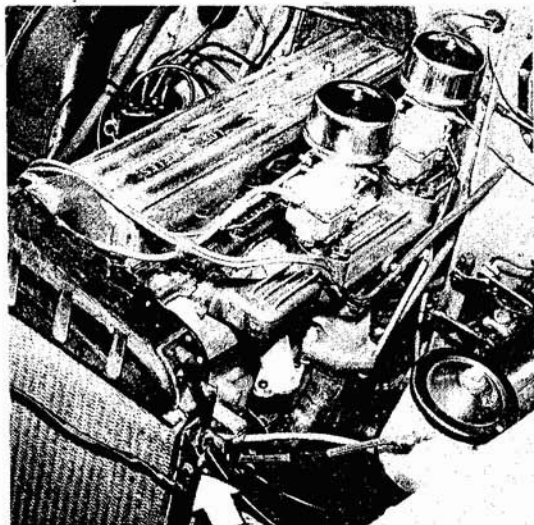

1950 Chev/GMC provides its owner with fast, dependable transportation. Arrow shows typical spacer used to move radiator 1.5" forward.

## HOW MANY HAIRY-LEGGED HORSES FROM A GMC?

| TYPE OF USE | CUBIC INCH DISPL. | EQUIPMENT   | HORSEPOWER OUTPUT |      |
|-------------|-------------------|---|-------------------|------|
|             |                   |   | Gasoline          | Alky |
| ROAD        | 292"              | 270 block & crank with early head, large intake & exhaust valves, dual carburetors, 3/4 cam, 8.5:1 compression ratio      | 180               | —    |
| HOT ROAD    | 292"              | 270 block & crank, 270H or 302 head, 1-11/16" exhaust valves, 3 carbs, full-race cam, 8.5:1 c.r.                          | 202               | 225  |
| HOT ROAD    | 320"              | 302 block & head, 270 or 302 crank, 1-11/16" ex. valves, 3 carbs, full-race cam, 8.5:1 c.r.                               | 225               | 255  |
| ALL OUT     | 292"              | 270 block & crank, 270H or 302 head, 1-11/16" ex. valves, 3 down-draft or side-draft carbs, super cam, 9:1 or more c.r.   | 225               | 260  |
| ALL OUT     | 320"              | 302 block & head, 270 or 302 crank, 1-11/16" ex. valves, 3 down- or side-draft carbs, super cam, 9:1 c.r. or more.        | 235               | 270  |
| MAXIMUM     | 292"              | 270 block & crank, FISHER 12-Port Head, two or six carbs or HILBORN injection. Super cam, compression as desired.         | 258               | 282  |
| MAXIMUM     | 320"              | 302 block, 270 or 302 crank, FISHER 12-Port Head, two or six carbs or HILBORN inject., super cam, compression as desired. | 282               | 305  |

**NOTE:** All ratings are approximate and from extensive experience we feel they are conservative. Ratings are for engines tuned for best fuel/air ratio and spark setting. Super fuels provide more horses. Ratings assume use of a dual-coil ignition system.

# THE CONSERVATIVE ENGINE

Producing from 165 to 185 reliable horsepower, depending on equipment and displacement, a GMC such as this provides exciting motoring at comparatively low construction and operating costs.

## DISPLACEMENT

Several displacement (engine size) combinations may be successfully used in a road engine. Most common is the 270 block and crank assembly using 3-15/16" pistons to obtain 292 cubic inches. My personal favorite is the 270 block bored to 3-15/16" and using a 228-248 crankshaft with 3-13/16" stroke. Although the displacement provided by this combination is only 279 cubic inches, little if any horsepower is actually lost since both piston speed and friction are markedly reduced. Such a combination provides better economy of operation and engine life than when the 270 4-inch crank is used.

To install the short-stroke crankshaft in a 270 or 302 block without sacrificing compression, .093" should be milled from the cylinder-head gasket surface. This is true only for the VENOLIA pistons and 270 heads. When using a 302-type head, mill the .093" from the block gasket surface to allow the flat-top pistons to come flush with the top of the block.

## LOWER END

Assemble the lower end, using stock GMC Morraine bearings, preferably the newer "400" type. Use stock clearances for the rod, main, and camshaft bearings. No extra clearance is needed or desirable. The crankshaft should be grooved. While the VENOLIA or FISHER pistons are supplied with .006" and .008" clearance on the skirt, one-half this clearance may be safely taken up by "knurlizing." You may order your pistons knurlized at slight extra cost.

Pistons, connecting rods, crankshaft, flywheel, and pressure-plate assembly should definitely be balanced.

## CYLINDER HEAD

Use an early 270 model with 1-15/16" intake and 1-11/16" exhaust valves. If you have any doubt in your mind about whether or not you might want to build a hotter engine later, buy a 270H or 302 head instead and install the valves recommended above.

## ROCKER ARMS

If you have a set of forged rockers, these may be used if the cam you install has mild valve action. These should of course be rebushed and installed on a new shaft. If a new set of rockers is needed, purchase the fabricated type, GMC No. 2193772.

## CAMSHAFT

A 3/4 or Super 3/4 camshaft may be used in this engine. Several are now available which provide a smooth and quiet idle which is difficult to distinguish from the stock grind. At the same time, they give good acceleration and top speed.

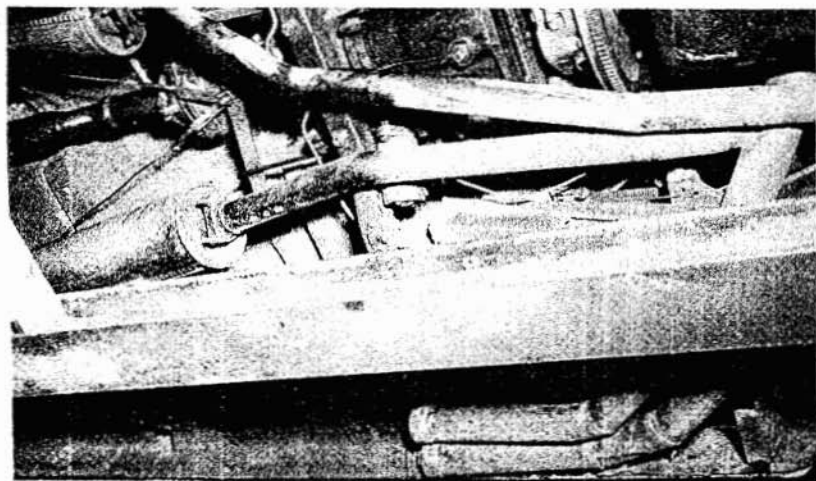

Under-chassis photo shows cross-over pipe to right muffler, and special header takeoffs. Installation shown uses 1949 Ford transmission, Lincoln overdrive and 26-tooth-cluster gears.

## CARBURETION

A dual carburetor intake manifold with STROMBERG BX-OV2 carburetors is recommended. Either a McGURK or NICSON unit may be used. It is best to buy the complete manifold assembly including carburetors, linkage, and fuel lines. Specify that you want the manifold "with heat" and indicate the type head with which it is to be used. If you plan to use a pair of your own carburetors, be sure to indicate the flange size you want (either  $1\frac{1}{4}$  or  $1\frac{1}{2}$  SAE). Otherwise, the manifold will be shipped with undrilled carburetor-mounting pads.

## COMPRESSION

The 8.5:1 compression ratio provided by the VENOLIA pistons is perfect for road use with ethyl-type gasoline. A  $\frac{3}{4}$ -grind camshaft should definitely be used with this ratio. When 3-15/16" bore flat-top pistons are used with a 302-type head, mill the cylinder-head-gasket surface .125" to obtain 8:1 compression.

## IGNITION

A stock Chevrolet distributor equipped with a FISHER two-coil conversion kit will provide positive ignition at any RPM you will want to operate your engine.

## EXHAUST

Stock GMC exhaust manifolds have ample capacity for road-type engines if large-diameter exhaust and tail pipes are used in conjunction with a single straight-through Buick muffler. If two mufflers are used with a split manifold or headers, use two stock-type mufflers, as steel or glass-pack types will be illegally loud.

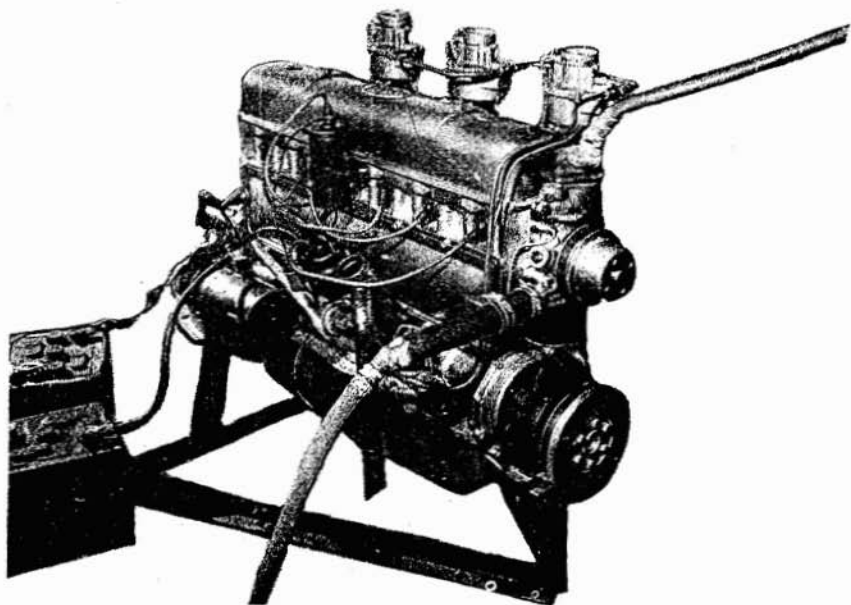

"Running-in" your GMC on a stand allows carburetor, tappet and linkage adjustments to be made while everything is still accessible.

## HOT-ROAD ENGINE

GMC's modified to this specification produce 195 to 225 H.P. on gasoline. When alcohol (methanol) is used, this jumps to a respectable 222 to 242 H.P. Maintenance and operating costs are greater than for a Conservative Road Engine.

### DISPLACEMENT

Use either a 270 or 302 block. A 270 bored to 3-15/16" provides 292 cubic inches with the stock stroke. The 302's may be bored to 4 1/8" to get 320 inches with the stock 4" stroke. Larger bores are not recommended.

**NOTE:** Either 270 or 302 blocks may be equipped with a 228-248 crankshaft to get a smoother, more economical engine. The shorter stroke provides less friction and lower piston speeds.

### LOWER END

Assemble the lower end with stock rod, cam, and main-bearing clearances. Use MORRAINE (stock GMC) bearings, preferably the new "400" series. When fitting solid-skirt FISHER or VENOLIA pistons, half the recommended clearance may be removed by knurlizing to provide improved oil control and quieter running. Fit slipper-skirt types to maker's recommendations.

Dynamically balance the rods, pistons, crank, flywheel and pressure plate before assembly. Modify block for full-flo oil filter. Provide four additional holes (7/16" SAE thread) in 270 cranks to retain a 1938-39 Chevrolet-truck flywheel.

## CYLINDER HEAD

A 270H or 302 head with 1-11/16" exhaust valves should be installed. While the intake guides may be tapered or chopped off, this will not add any measureable horsepower and will increase guide wear greatly.

Careful attention should be taken to remove all sharp edges, casting irregularities, and ridges from the combustion chambers. If a cc. glass is available, the volumes of all combustion chambers should be equalized.

While the 302 head must be used on the 302 block on all bores larger than 4", use of the 302 head on the 270 block is possible and recommended since it permits the use of high compression ratios without need for premium gasoline. Flat-top pistons must be used with the 302 head.

## ROCKER ARMS

Use fabricated type, GMC No. 2193772.

## CAMSHAFT

Install a full-race camshaft in this engine. When you order, we will be happy to recommend a suitable grind which will provide outstanding acceleration and top-speed performance.

## CARBURETION

Install a three-carburetor downdraft manifold with exhaust heat box. STROMBERG carburetors are recommended. HOLLY, ROCHESTER or ZENITH may also be used. It is wise to buy the manifold as a complete assembly, which includes properly adjusted carburetors, linkage, and fuel lines. If using your own carbs, specify flange size when ordering, or the manifold will be shipped with undrilled carburetor-mounting pads. Install air cleaners on the carburetors. A stock fuel pump, or one of the new CARTER replacement types M751 or M779 will supply adequate fuel for the three carbs.

## COMPRESSION

Approximately 8.5 or 9:1 compression is recommended. This will not usually cause excessive detonation, since the additional overlap provided by the cam actually reduces the effective compression ratio.

Mill your 270 head .0625" (1/16") to get 9:1 compression with the VENOLIA pistons. Mill your 302 cylinder head .125" for 8.7:1 compression with a 4 1/8" bore. Other ratios are indicated in the table in the Head Section.

## IGNITION

Modify a stock Chevrolet or GMC distributor with a FISHER dual-coil conversion kit.

## EXHAUST

Install a set of cast-iron headers. Use dual stock mufflers. Header take-offs may be provided if occasional racing is contemplated. See Exhaust Section.

# ALL-OUT GMC RACING ENGINE

The amount of horsepower produced by all-out engines depends greatly on the owner's or mechanic's tuning ability. In general, such engines operated on gasoline fuel and used with a reworked stock cylinder head will produce from 215 to 236 H.P. With the FISHER 12-Port Head and gasoline, output will be from 258 to 285 H.P., depending on displacement and equipment. When alcohol/nitro-methane fuel is used in these engines, horsepower increases proportionately so that a 292" 270 produces well over 300 H.P. with the FISHER head, or as much as 290 H.P. with a reworked stock head.

## DISPLACEMENT

Use as much displacement as allowed by the rules; however, bores which are excessively large should be avoided since they actually cause horsepower loss at high RPM's. This is due to the fact that "ballooning-out" at the middle of the cylinder prevents proper ring action. This creates excessive blow-by which cannot be eliminated, even with very severe rings. Horsepower blown into the crankcase does you no good at the rear wheels! A 3-15/16" bore should be considered maximum for 270 engines. While 4" bores in 270 blocks have been known to provide good service, they will usually "poop-out" under pressure. Stroking provides additional low-speed torque, but does not add much, if any, additional H.P. at top RPM's. Most fellows find that their stock 4" stroke engines are the most reliable.

## LOWER END

Pistons, rods, crankshaft, flywheel and pressure plate must be balanced! Crankshaft main-bearing journals should be grooved for additional oil supply to the connecting-rod bearings.

**NOTE:** There is some disagreement among GMC owners as to whether grooving a crank is beneficial or detrimental. Stock GMC engines have remarkable lasting qualities with their "ungrooved" crankshafts, but the high RPM developed by modified engines makes grooving a necessity.

If you are using a 270 crank, it is absolutely necessary to drill and tap four holes in the crank flange for additional flywheel retaining bolts (7/16" SAE). Chevrolet bolts are used. Matching holes must be provided in the flywheel.

When grinding the crankshaft, provide an additional thousandth oil clearance by finishing the journals undersize. In other words, instead of grinding the rod and main journals to .010, finish them to .011 undersize.

Use stock GMC rod and main bearings (MORRAINE). No align boring is needed, nor are all-steel center-main-bearing caps needed. Stock "heavy" main caps may be strengthened by modifying them as per the following drawing. This method is superior to the installation of a machined pair of steel caps, since the complete caps must be align-bored to fit each block. This is a needless expenditure.

Solid-skirt pistons should be fitted with from .012" to .016" clearance, slipper skirts with .008" to .010" depending on manufacturer recommendations. Fit wrist-pins in pistons with an easy thumb-press fit at room temperature. While this is considerably looser than is usually considered good practice, it is essential to insure that the pin will be able to turn in the piston in the event of rod-bushing seizure.

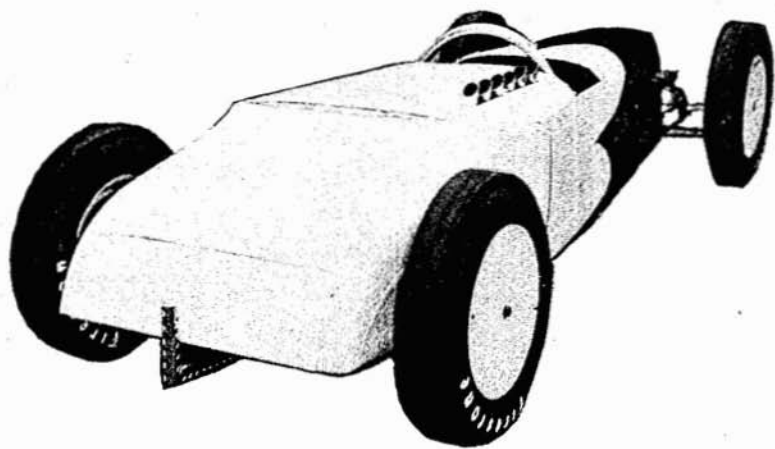
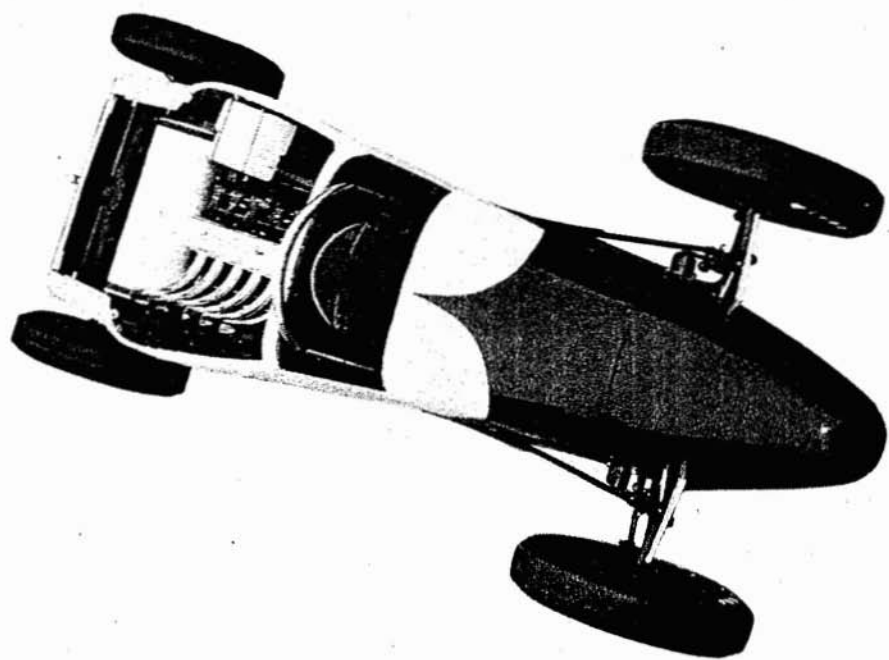

Using FISHER head and accessory-drive assemblies in conjunction with a 270 GMC block bored to 292 cubic-inch displacement, Lawrence Brocchini and Roy Semas booted "Snoot" to 166.66 mph at the 1954 Bonneville National Speed Trials. The car also uses a HILBORN Fuel-Injection System, HOWARD F-7 Cam, FISHER Pistons, and a MEYER-DRAKE Water Pump. Photos are presented courtesy of MOTOR LIFE, which magazine featured the car in their October 1954 issue.

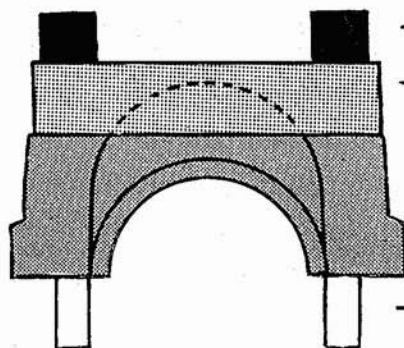

- NEW ALLEN-HEAD CAPSCREWS
- STEEL CAP 1" TO 1.5" HT.  
1.25 WIDE BY 4.75 LONG
- STOCK G.M.C. HEAVY-MAIN  
CAPS, CENTER TWO ONLY,  
CUT OFF FLUSH WITH BOLT  
BOSSSES— USE LATHE · MILL
- THREAD PROTRUDES 1-INCH

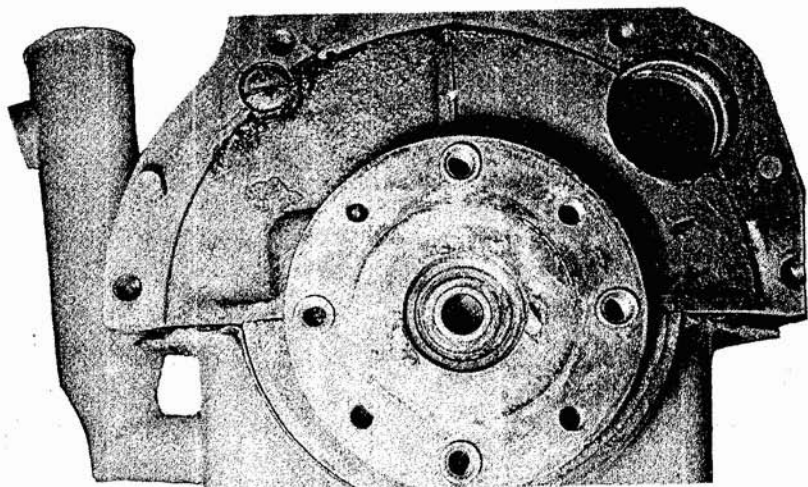

Hot "Jimmies" need to breathe in more ways than one. To eliminate oil blowing all over your engine, install two 1950 Chevrolet breathers on the left side of the pan above the normal oil level. Take care that they clear throttle, steering, and exhaust components. Two accessory breathers should be installed on the pushrod cover. Note the extra holes for the flywheel.

## CYLINDER HEAD

Modify a 270H or 302 cylinder head per the directions in the Head Section, or install a FISHER 12-Port Aluminum Cylinder Head.

## ROCKER ARMS

Use fabricated type, GMC No. 2193772.

## CAMSHAFT

Use a super racing grind camshaft. Several are available, and of course—each manufacturer says that his is the best. We prefer to recommend a camshaft when you place your order, since rapid advances occur in this field from month to month.

## **CARBURETION**

Use either three downdraft, five downdraft, or three sidedraft carburetors on a reworked stock head. FISHER heads may be used with two sidedraft carburetors, fuel injection, or custom manifolds. Use alcohol fuel if it is permitted. If you fail to do so, you accept a terrific handicap. See Fuel Section for details on the use of this potent fuel. Remember that the entire fuel-supply system, as well as the carburetors, must be reworked to use methanol.

## **COMPRESSION**

There is a common misconception which says that you should use all the compression possible with alcohol fuel. Our own, and the experience of others indicates that this is not the case. Somewhat lower compression with a well-tuned engine will produce more H.P. than those fantastic ratios of 14 and 16:1 which are often recommended.

Look at it this way — Consider your engine as an air pump, for that is what it actually is. When compression is increased, the power extracted from the fuel is also increased (provided detonation does not occur). If the compression is increased to the point where the engine does more work in compressing the charge than it gains back from increased power, then a point of no return has been reached. Just where this point occurs would be hard to say without expensive and extensive tests, and it will certainly vary with individual engines. The point is affected by camshaft duration, cylinder-head combustion-chamber design, cylinder-head material, and displacement. Personal experience leads me to believe that approximately 9:1 is the most which can be used on gasolines which are generally available today. 12:1 is a good maximum figure for either the FISHER or reworked GMC heads for use with methanol fuels.

## **IGNITION**

Use a dual-point, dual-coil distributor — or a VERTEX (Scintilla) Magneto. Don't handicap your all-out engine with a mediocre ignition system. The FISHER two-coil conversion kit allows you to convert your distributor for positive, high-RPM operation at low cost.

## **EXHAUST SYSTEM**

Use exhaust headers. No exhaust heat should be used on the intake manifold. Equip track cars with a system to carry the exhaust to the rear. Ending the header at the firewall saves only a little weight, and may allow choking fumes to billow into the driver's compartment. Drag-race machines should use headers as short and lightweight as permitted. Direct the exhaust away from the driver.

Mufflers are seldom used on all-out engines. If such an engine must be run with mufflers, make sure that the muffler system is adequate. Do not choke off the horsepower which has cost you so much money to obtain. It isn't good economics!

If you can secure the services of an engine-test-laboratory's dynamometer, by all means do so. The money expended will be repaid by increased performance.

# SINGLE-CARB TRACK ENGINE

Many "Sportsman" racing clubs throughout the United States allow the 270 or 302 GMC engine to be used in a Chevrolet chassis, providing the exterior of the engine retains a completely stock appearance. "Anything goes" on the interior!

## DISPLACEMENT

Use every cubic inch the association allows. Others will do so, and you accept a needless handicap unless you follow suit. Remember that cubic inches are the cheapest way to get additional horsepower.

## LOWER END

Balance pistons, rods, and crankshaft. Flywheel and pressure plate should also be balanced. Add four flywheel retaining holes in 270-type crank flanges. Drill and tap these for 7/16 SAE Chevy crank screws. Groove crankshaft journals. Modify block for full-flow oil filter. Grind crank an additional thousandth undersize to provide additional oil clearance. Use MORRAINE "400" bearings throughout.

Fit solid-skirt pistons with .012" to .016" clearance, slipper-skirt types with .008" to .010". Wrist pins should be fit into pistons to provide an easy thumb-push fit at room temperature (70°F).

## CYLINDER HEAD

Modify a 270H or 302 cylinder head per the directions in the Head Modification Section.

## ROCKER ARMS

Use fabricated type, GMC No. 2193772.

## CAMSHAFT

A slightly different type of camshaft is required for this type of racing. Install a grind which provides higher lift than a Full-Race Grind, with shorter timing (duration of valve opening). We will be glad to recommend a cam which will produce peak power from a single carburetor.

## CARBURETION

Use the 270H intake manifold on either a 270H or 302 head. This manifold has slightly better porting than the 302 manifold. Although no dual-throat carburetor will adequately supply the breathing requirements of a modified GMC engine, the Stromberg Type EE-22 (used on some early Buicks) has been tested and found to work quite well. An adapter must be purchased (or made) to fit the four bolt carburetor flange to the two bolt pattern of the 270H manifold.

If alcohol fuel is permitted — USE IT! Modify the above carb as follows to use this type of fuel. Other details on "alky" are contained in the Fuel Section.

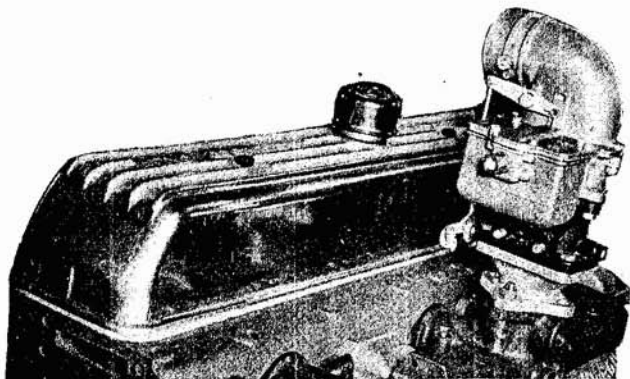

Stromberg EE-22 shown on adapter which allows its use with 270H manifold for use with 270 or 302 heads.

|           |       |                  |       |
|-----------|-------|------------------|-------|
| MAIN JETS | .086" | NEEDLE SEAT      | .120" |
| IDLE JETS | .033" | DISCHARGE NOZZLE | .136" |

Drill discharge nozzle almost through to end, then file notch in underside to disclose .136 diameter.

We do not feel that a 4-barrel carburetor will provide any more performance on the track.

## COMPRESSION

Modify your cylinder head and/or block to obtain approximately 9:1 compression for gasoline or 12:1 for alcohol fuel.

## IGNITION

If ignition modifications are allowed, use a FISHER two-coil conversion on your Chevrolet or GMC distributor. If nothing extra can show on the outside of the distributor, use a set of high-speed points in the distributor, and set them at .012". Spark plugs for this type of racing are usually CHAMPION J-6 or J-3 for gasoline, or J-2, J-3 for alcohol blends.

## EXHAUST

Make the exhaust system as light as possible. If the stock exhaust manifold must be used, install as many additional outlet flanges as are permitted. Straight-through exhaust pipes should be routed to the rear of the car, since a header which ends just under the firewall pours choking fumes into the cab, causing extreme driver discomfort.

## OIL TEMPERATURE

Where engines such as these are used for daytime racing, the oil temperature often gets excessively hot. To avoid the possibility of bearing failure from this cause, insert an oil cooler in the full-flo-filter circuit. We can provide these coolers, together with the necessary regulators.

Wallie Branston, of Toronto sent me this information on how he has set up his highly successful single-carburetor competition job. It may provide some good ideas for your own machine. Remember to get that GMC as large as possible, and use a cam designed for the purpose. Every pound of weight you can toss out puts you that much nearer to the checkered flag. Here's Wallie's letter:

Dear Bill:

O.K., hang on to your cap chap, here we go. Just keep it south of the border, as it really works.

The frame must have an overall twist of approx. 7", obtained by tying down the right-front and left-rear corners, and jacking up the opposite corners. This places the weight on the right-front and left-rear wheels.

|        | <u>ALIGNMENT</u>                          |                        |
|--------|---|------------------------|
|        | Right                                     | Left                   |
| Camber | 1-1/2 degree positive                     | 3-1/2 degrees reverse  |
| Caster | 1 degree positive                         | 2-1/2 degrees positive |
| Toe In | 1/2 inch with the wide slick on the right |                        |

Tires for paved track: Left front, 6.00x16;  
right rear, 7.00 x 15, 8" slick;  
and left rear, 7.00x15, 6" slick.  
Pressure according to track surface  
and weight of car.

Chain the left-front corner with not more than 1-1/2" slack. Pull the right front end of the axle forward 1 to 1-1/2".

Springs: Left front, stock spring with two leaves removed, ends trimmed to clamps; right front, stock spring with four extra leaves; no arch in either front spring. Right rear, heavier than stock spring with three extra leaves, no arch. Left rear is the same as right, with only one additional leaf. Shocks are set up according to the track surface. With this set up, when full power was applied on the corner, the back end would drift out nicely. Steering is set up according to the driver. In order to tow the car with this set up, a 4.75x15 tire is required on the right front, and a 6.00x16 on the left.

Well, that's it, Bill. I'm changing a few more things this year to get it around the corners still faster, including moving the engine back. Will write again soon and send more photos.

Wallie

# REWORKED VS. STOCK CHAMBERS

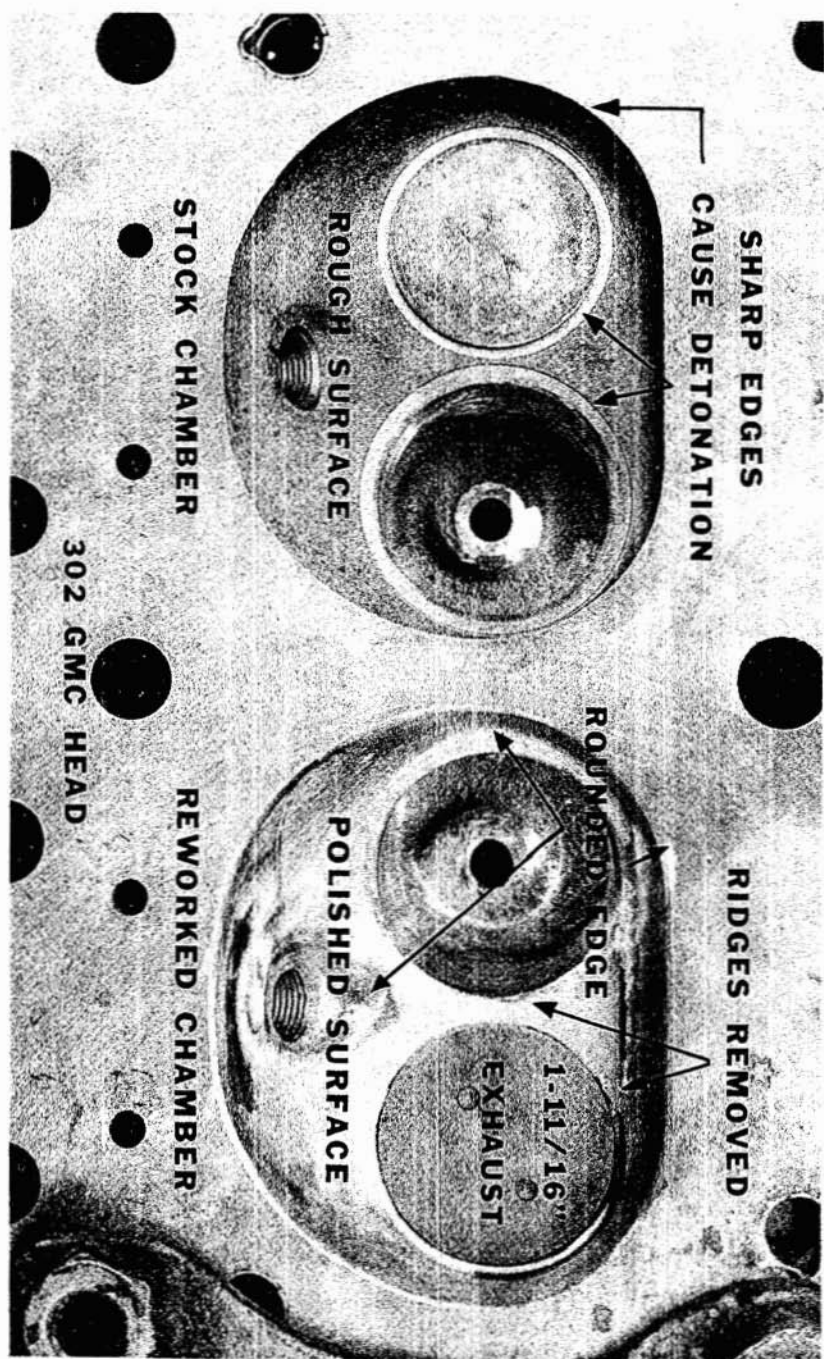

# CYLINDER HEAD

The three types of stock GMC heads currently available, plus the FISHER 12-PORT, provide a wide range of choice for the GMC enthusiast. Each of these assemblies may be used on the 270 and 302 blocks and consists of the same basic component parts which include: cylinder head, valve guides, intake and exhaust valves, valve springs (single or double type), locater washers, spring retainers, valve keepers, water-temperature fitting, rocker-arm oil-line fitting, copper rocker-arm gasket, and head bolts. Also included are the combined water neck and thermostat housing — and perhaps most important, a 180° thermostat.

## WHICH HEAD?

While any of these four heads can be installed on your 270 or 302 block, the choice is somewhat simplified when the variables are considered. First of all, don't scoff at the seemingly tiny ports of the early-style 228 through 270 heads, as these are actually the best for pleasure-car use. They not only provide better low-speed carburetion, but also provide smooth idling and excellent city-driving performance. They will usually provide more miles per gallon of gasoline than the larger ports of the 270H and 302 heads.

All of the aforementioned features are important to consider *if your wife must drive the car — believe it!*

The 270H and 302 heads are recommended for hot road jobs and competition engines used for drag and top-speed racing. As shown elsewhere in the manual, these are interchangeable on 270 and 302 engines, providing the proper pistons are used. The 302 is actually somewhat better than the 270H head, since its D-shaped, quench-type combustion chamber provides the additional advantages of resistance to detonation and ping.

The FISHER HEAD is for the GMC owner who wants the utmost performance from his engine.

## EARLY 270 HEADS — 2071456

Smooth the combustion chambers, round the combustion-chamber edges, install 1-15/16" intake, and 1-11/16" exhaust valves. Blend the alignment-ring counterbores into the general contour of the siamese intake ports. Remove rough spots from the ports, but do not polish. A 1 3/8" shell reamer can be run into the ports about one inch and the resulting bore blended into the rest of the siamese intake port. We usually blend in the counterbores and remove the rough spots with a die grinder and skip the reamer operation, as the intake ports of the early heads are notoriously thin.

## 270H CYLINDER HEADS — 2193505

For really hot road jobs or all-out competition engines, the 270H head works out very well. For conservative use, the 270H provides slightly rough low-speed performance and is not usually used unless the owner is desirous of maximum performance in the range above 4000 RPM. The larger ports of the 270H head will not cause an engine to "sign off" from lack of breathing at high RPM. If there is a doubt in your mind as to the performance you want from your engine, buy this head or a 302 head and you'll not be sorry later if you want to go all-out.

For hot road jobs, smoothing the intake-port alignment-ring counterbores into the port contour is recommended, together with matching the intake manifold to the intake ports. Install dowels for positive alignment. In addition, the valves should be replaced with 1-15/16" intakes, 1-11/16" exhausts. The combustion chambers must be smoothed out, and their edges rounded. Special care should be paid the ridges around the valves, since these will become red hot and cause detonation if they are allowed to remain. Do not waste your time polishing the ports or trying to enlarge them further. They are already monstrous and polishing will not measurably assist the airflow into the cylinders.

**NOTE:** In smoothing out the intake ports, you may "hole-through" one of the head-bolt holes due to their very close proximity to the port wall section. If you do, use a flat washer, well coated with Permatex, under the head of that particular head capscrew. This will prevent leaning-out of the mixture, possible burning of a piston head or valve, or detonation during full-throttle operation.

### 302 GMC CYLINDER HEAD — 2194156

A stock 302 GMC Cylinder Head is a potent piece of racing equipment as it comes from the factory. However, mild reworking enables its full potentialities to be fully realized. Superior to the 270H style from several stand points, including slightly lower cost, the 302 heads may be installed on 270 blocks when the proper flat-top pistons are used. The "D-Shape" 302 combustion chamber is similar to that used by Cadillac and Oldsmobile and its quench area provides the advantages of high compression together with good resistance to both detonation and spark knock.

Although already large, the siamese intake-port contours may be faired into the alignment-ring counterbores. Further enlargement or polishing is not necessary. Stock 1 $\frac{5}{8}$ " exhaust valves should be replaced with 1-11/16" valves for best performance, especially with heavy valve-spring combinations, as the stock 302 exhausts cannot be used with the required competition-type spring retainers. Since no hard seats are used in the 302 head, enlarging the exhaust ports is a simple process involving only the use of a 60° or 70° reamer or valve-grinding stone. Reseat with a 45° stone. Blend in the port contours somewhat, but don't waste your time enlarging the exhaust ports as they already have adequate dimensions.

If you plan to use a 302 head on a competition engine, the stock intake valves should be replaced with 1-15/16" valves for a marked improvement in breathing.

### EFFECTIVE VALVE AREAS OF STOCK VS. OVERSIZE VALVES

|  |                      |
|--|----------------------|
| 1- $\frac{3}{8}$ " stock exhaust valve | = 2.16 square inches |
| 1- $\frac{3}{8}$ " stock intake valve  | = 2.55 square inches |
| 1-11/16" oversize exhaust              | = 2.65 square inches |
| 1-15/16" oversize intake               | = 3.04 square inches |

A convincing argument for oversize valves is almost shouted by these figures, which show effective valve area at 0.5-inch lift. The effectiveness of big valves is greater than stock from the moment valve lift begins. For some excellent and accurate information on valve lightening, valve size, and port sizing, see Chuck Eddy's fine CAR CRAFT MAGAZINE articles in the September and October 1954 issues.

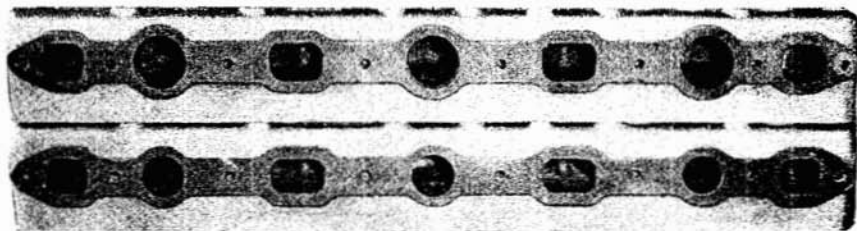

A graphic comparison of intake-port size: 270H or 302 head atop an early 228 through 270 model. Later head has over 50% more intake-port area, is ideal for high horsepower production.

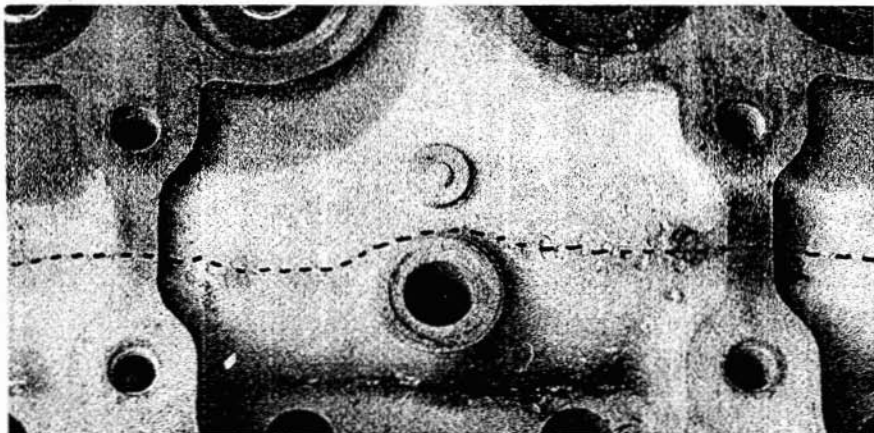

Used heads should be sandblasted and carefully examined before reworking, since cracks often appear in the area shown. Cracked badly, this head was not suitable for reuse.

## COMBUSTION CHAMBERS

The rough, sand-cast finish of the stock-head combustion chambers gets very hot and causes detonation, a phenomena which greatly reduces engine life. The combustion chambers should be smoothed out and the edges rounded, regardless of the type of use to be given the engine. Smooth the surfaces with first rough, then fine sanding discs or drums. If a grinder is not available, the polishing can be done with successively finer grades of emery cloth mounted in a slit rod which is chucked in a  $\frac{1}{4}$ " drill.

## PORTING

While porting the stock cylinder heads is a simple job (no porting is required on the FISHER HEAD) if the proper tools are available, we are equipped to handle these details for our customers. Before porting a used head, or doing any work on it at all — sandblast it! Then check it carefully for cracks as the GMC heads are prone to cracks along the top. Although cracks can sometimes be successfully repaired, it is best to start with a head which shows none.

## BIG EXHAUST-VALVE INSTALLATION

Stock-size GMC exhaust valves in early or late 270 and 302 cylinder heads will not adequately handle the exhaust produced by a hopped-up GMC engine, and their use will restrict essential breathing. Our dynamometer tests have conclusively proved that the addition of a set of 1-11/16" exhaust valves will add as much as ten horsepower to the output of a 292-cubic-inch GMC engine, with larger increases from bigger engines. These valves are available from us, ready to install.

The first step in their installation is the removal of the hard exhaust seats from the cylinder head. This is accomplished with a chisel bent to fit through the exhaust ports, and a very large hammer. The seats are usually difficult to start out, but once they begin moving, the battle is won! Since the seats are extremely brittle and subject to disintegration from the concentrated pressure required for their removal, it is wise to wear safety glasses or an eye shield when removing them. There is plenty of metal at the point where the chisel contacts the back side of the seat, so don't worry about going through into the water jacket with the chisel.

Remove the exhaust hard seats and blend-in the ridge on the solid side. Do not grind straight down except where this can be done without going into a port wall. The solid sides of the port must be smoothly tapered into the general port contour. Avoid that temptation to grind straight down or you'll be buying some expensive water-jacket repairs — or even a new cylinder head.

Extreme care is needed to make sure the grinding wheel does not contact the edge where the valve pocket meets the combustion chamber. This rim becomes the 45° seat for the 1-11/16" exhaust valve. To keep exhaust-guide temperature down, grind these off until they are even with the "roof" of the port. The 1-11/16" valves have a slightly larger-than-stock diameter and an adjustable guide reamer is required for their installation. Your local auto-parts house should be able to handle this for you.

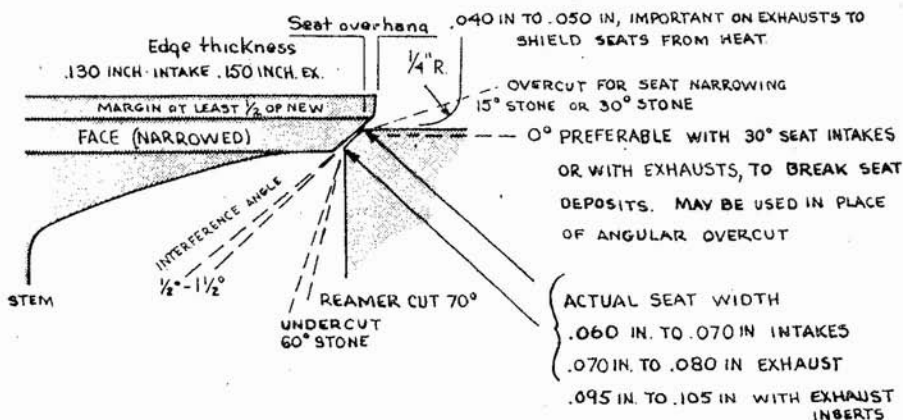

Angles and widths for grinding or reseating your valves. All measurements pertain to a lightened and reshaped valve. Diagram courtesy Car Craft Magazine.

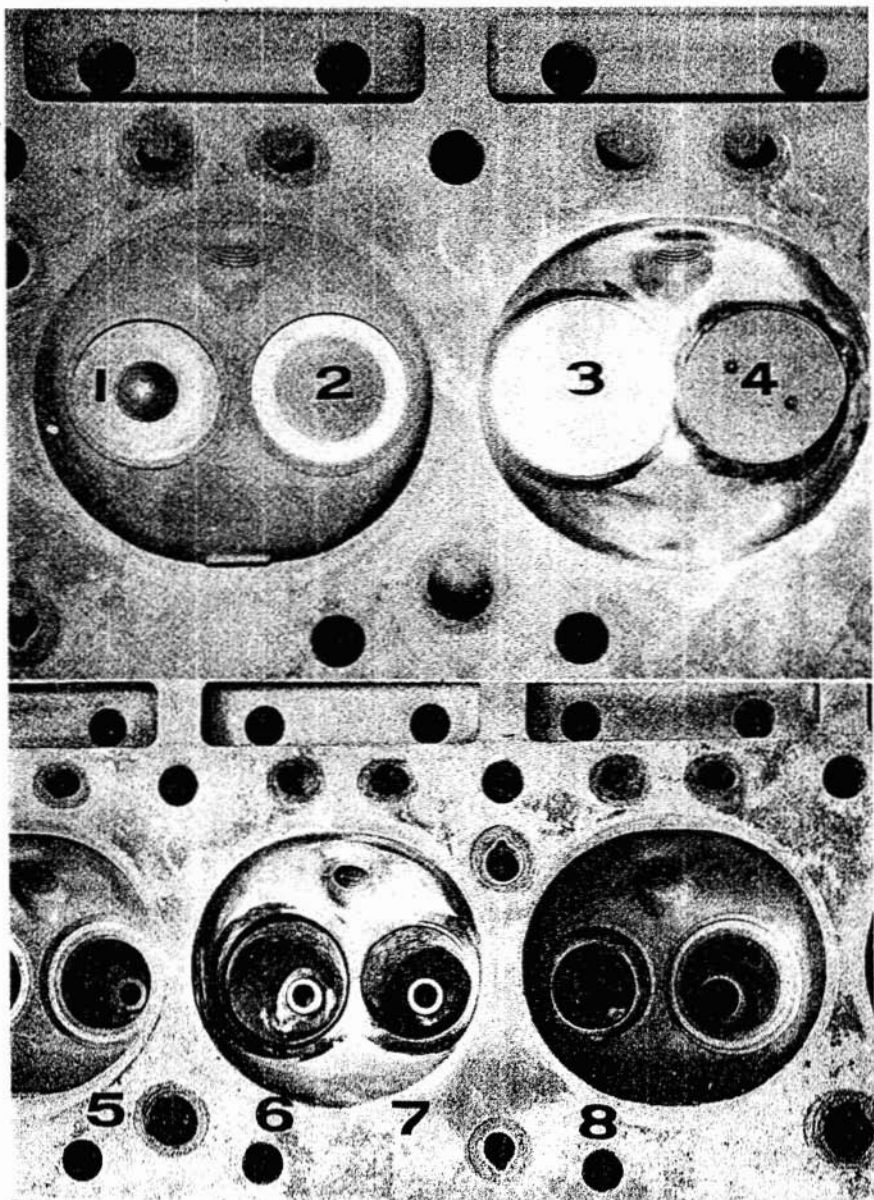

Early 270 head with (1) stock exhaust valve, (2) stock intake, (3) 1-15 16" lightened intake, and (4) 1-11 16" special exhaust. Lower photo of same head: (5) stock intake port, (6) reworked (ported) intake port, (7) reworked exhaust, (8) stock exhaust with hard seat removed prior to porting operation. Note polished center chamber. Smooth combustion-chamber surfaces are more important than glass-like ports.

McGurk triple-carburetor manifold with Stromberg BX-OV2 carburetors. This same manifold is available in five-carburetor form at slight additional cost. McGurk cast-aluminum rocker-arm cover is also shown, together with Nicson cast-iron headers.

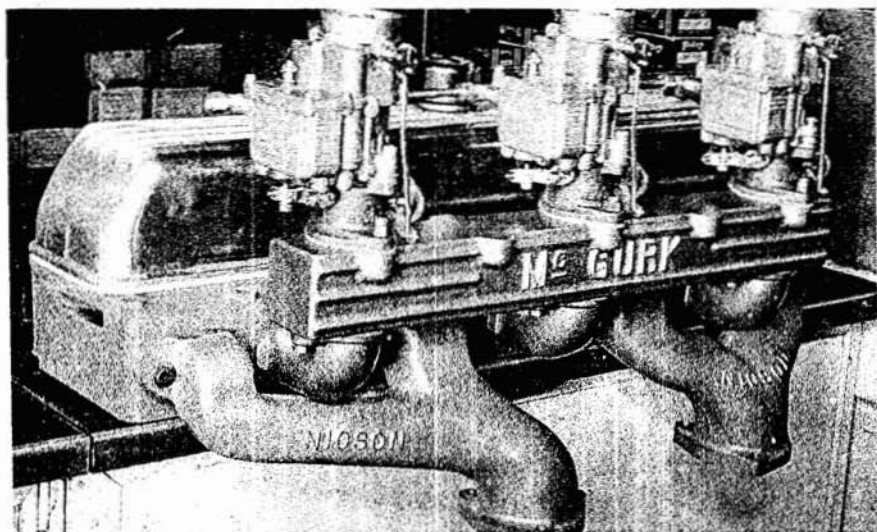

Even though the factory takes the trouble to stamp "UPPER" and "LOWER" on the rear-main bearing halves, GMC's are occasionally assembled with these reversed, cutting off oil to the rear-main and No. 6 rod-bearing journals.

## GMC VALVE COMPONENTS

Many cams available today provide lift at the valve up to as great as  $\frac{1}{2}$  inch. Thus, extreme care must be used when installing valve guides, valve springs, pushrods, and retainers *if expensive noises are to be avoided.*

Points to watch for are allowance of at least  $\frac{1}{16}$ " clearance between the bottom of the retainer or oil seal and the top of the guide when the valve is at maximum lift. Otherwise, bent pushrods, broken tappets, broken rocker arms and shafts — *and long sad faces will inevitably result.*

Outer valve springs should be compressed to a total installed length of  $1\text{-}27/32$ " with the valve on its seat. If inner springs are used, a special competition type is required. Don't be tempted to use the slightly cheaper Buick inner valve spring as these become "coil-bound" when installed with almost any of the  $\frac{3}{4}$  or more radical camshaft grinds which are usually supplied.

A further point of consideration is that high racing speeds sometimes cause early valve-spring failure, especially when the springs are compressed farther than intended by the designer. Thus, it is wise to replace all of the valve springs in a "super" or "all-out" engine at least once a season; those in a pleasure car, at least once per year.

For a positive check on the correctness of your installation, make the following test after installing the head and setting the tappets. With the number-one cylinder on the intake stroke at Top Dead Center, press down on the rocker arm to make certain that the valve can be opened at least  $\frac{1}{32}$ " farther without meeting any solid obstruction or resistance.

Tubular-type pushrods are considered standard, even for road-job use. Made of .057"-wall seamless-steel tubing, these pushrods will withstand high RPM and the heavy valve-spring pressures without flexing or bending.

### WARNING

All tappet adjustment screws must be fully backed off before attempting to bolt the rocker-arm assembly into place. Otherwise, at least one or more pushrods will be bent by the tremendous pressure of valve springs holding the rockers at unusual angles against pushrods already at maximum lift.

Pushrod length depends on several factors, including the type of camshaft to be used, the amount milled from the cylinder head and/or block, and the height of the valve stems above the cylinder head. The angle of the rocker arm should be adjusted by varying the valve-stem height so one half of the rocker-arm action occurs each side of horizontal.

Tappets of either the early "deep" type or the later ones with the high cup may be used. Each has advantages and disadvantages. The lighter, deep type requires a longer pushrod which is more subject to flexing at high RPM. The slightly heavier later type are used with shorter, more rigid pushrods.

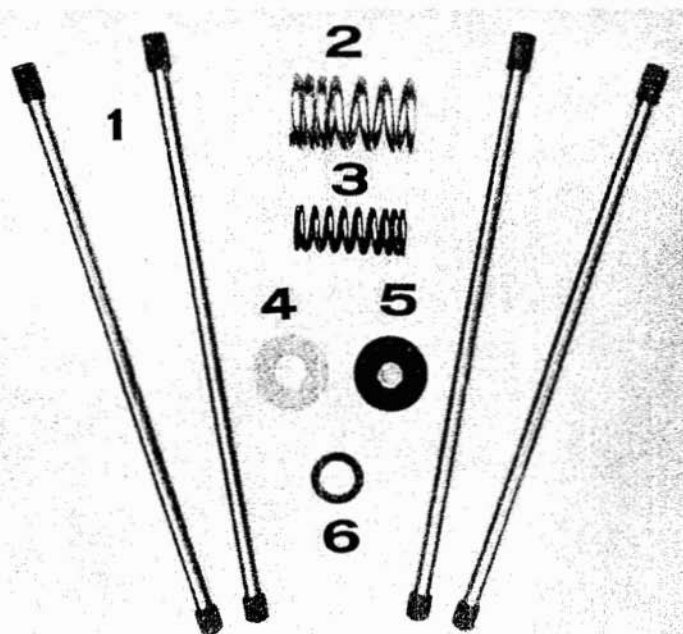
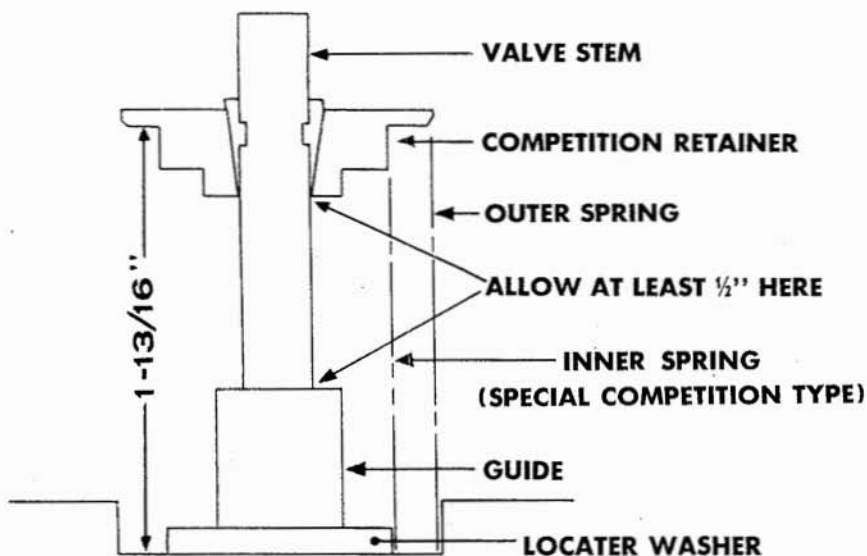

Essential GMC valve goodies shown here include: (1) Tubular Push-rods, (2) Outer Spring, (3) Special Inner Spring, (4) Tension Washer, (5) Competition Retainer, and (6) Locator Washer.

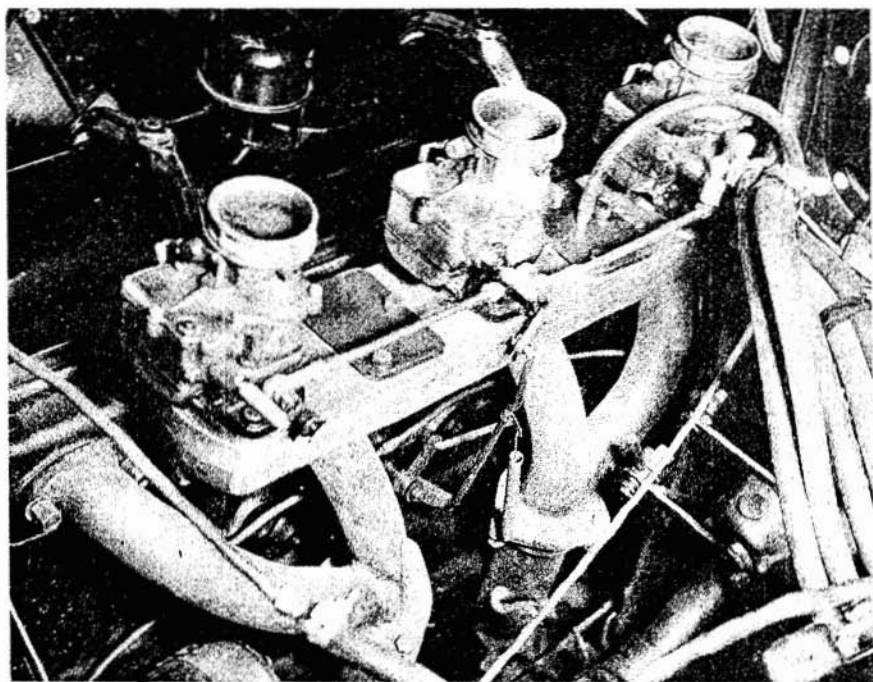
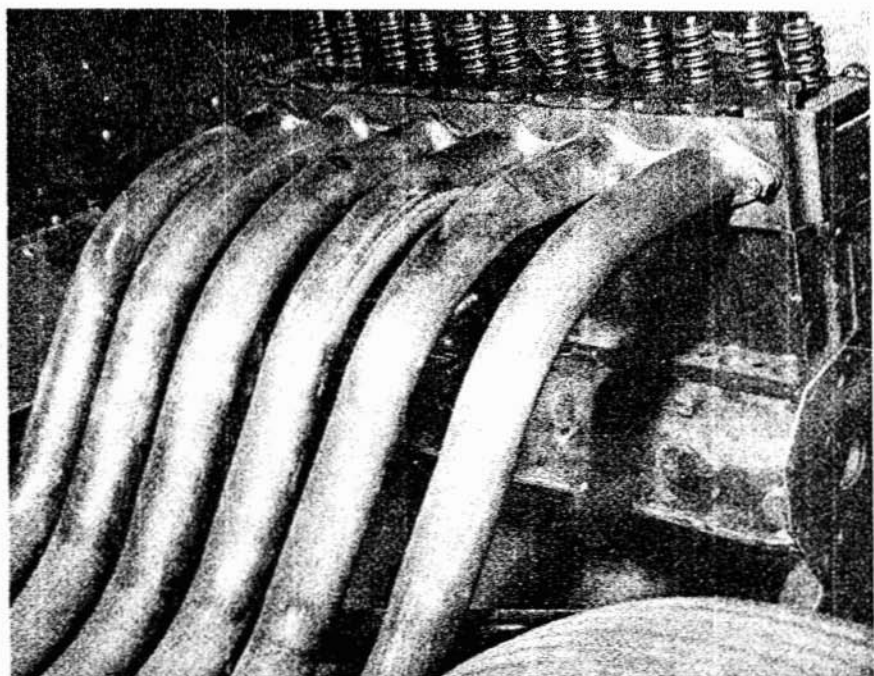

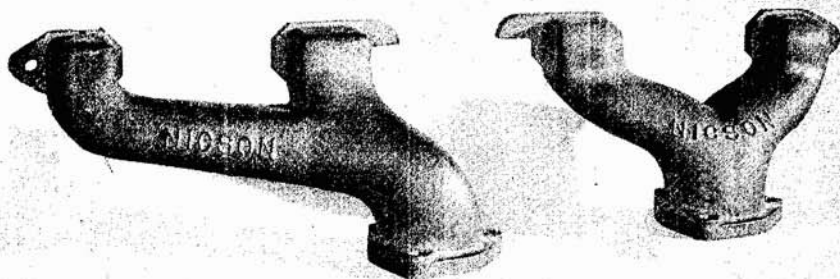

Nicson cast-iron headers are designed for GMC engines. Burn-out proof, they provide positive gasket sealing.

## EXHAUST SYSTEMS FOR YOUR GMC

For the economy-minded GMC owner, as well as those who want maximum performance, an efficient exhaust system should be considered essential. Many who give their engine loving care during assembly forget that, as do humans, *engines have to exhale*. Every modification described in this manual, with one or two exceptions, is designed to make your engine breathe better. Don't nullify much of your modification work by tying your GMC onto a stock or inadequate exhaust system which can easily cause a rear-wheel-horsepower loss of 30 or more ponies. Either fabricate your own exhaust system or get it done by an exhaust specialist, as the Chevrolet components will not fit. If you wish to use a single muffler, then get a large-diameter Buick straight-through type with matching tailpipe.

Dual exhaust systems are preferred by most builders due to their added efficiency and sound. Dual systems may be installed by using a stock GMC exhaust manifold to which an extra outlet has been added. Cast-iron headers with outlet flanges matching GMC exhaust pipes are also available. These new headers provide positive gasket sealing where the headers join the head, a feature not available with Chevrolet types, sold for GMC use.

As the accompanying photographs show, headers can be made by the individual engine builder if he is a torch artist. *Header making is definitely not for the novice.*

Dual exhaust systems will work very nicely with a pair of stock Chevrolet mufflers, but will prove most efficient when installed with stock straight-through units.

If your machine is used occasionally for competition, install a set of header takeoffs. These can be Chevrolet gas-tank filler necks and caps. Weld them onto the exhaust pipes, just ahead of the mufflers. A system thus installed is legal for street operation, yet ready for competition on a moment's notice.

**NOTE:** Before you drive the car after installing an exhaust system, check that all of its components clear the steering, brakes, clutch, and gear-shift linkage.

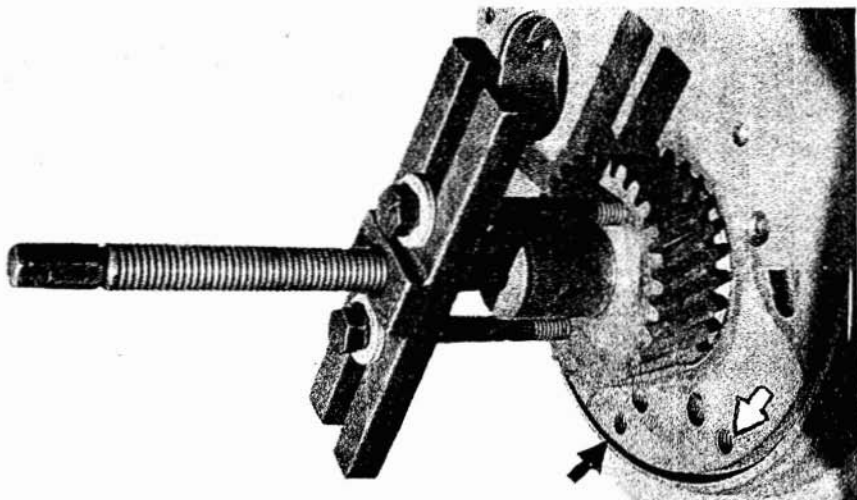

T-type gear puller for Chevy-GMC crank pulley and gear. Arrows indicate holes to be tapped for  $\frac{3}{8}$ -16 to permit easy timing cover and camshaft removal.

## HOW TO STRIP YOUR SHORT BLOCK

Carefully disassemble your short block assembly as follows: Remove the oil pan, oil-line fittings, oil-pump lock nut and set screw, and the oil pump. Remove the rod caps, checking that both cap and rod are numbered (on the camshaft side) to permit correct assembly. Ream out the ridge at the top of each cylinder, and tap out the pistons. **DO NOT POUND ON THE RODS!** The cylinders of rusty blocks should be soaked with penetrating oil before attempting to remove the pistons by directing hammer blows through a steel drift placed against the piston wrist pin bosses. Remove the crankshaft pulley with a gear puller which pulls against two cap screws threaded into the pulley hub. Remove the two cap screws on the inside of the front-main cap and the small cap screws which attach the timing-gear cover to the front of the block, and remove the cover. Turn the crank until the two camshaft-gear holes align with the screws which secure the camshaft-retaining plate to the block. Remove these, check that the No. 1 piston is at Top Dead Center, and remove the camshaft. Use the gear puller again, this time on the crankshaft gear. Remove the three fillister-head screws and two cap screws which secure the front motor plate, and tap off the front plate. If you are making a GMC-Chevy installation, you can throw away the plate, since you'll be using a Chevrolet passenger-car type.

Remove the main-cap bolts and main caps, remove the crankshaft, and discard the rear-main oil seals. Also remove and discard the timing-cover seal. Remove all of the block freeze plugs. This is usually done by driving a small chisel into the plug and prying outward. Remove the rear camshaft plug, and drive out the camshaft bearings with driving bushings. The bushings are available from us, or you can get the job done at your local auto-parts house.

The plug at the rear and the fitting at the front of the oil galley should be removed and the galley rodded out. Before further work or cleaning is done to the block, modify it for a full-flo filter, and get it bored. Then have it soaked overnight in a cleaning tank and steam cleaned afterward.

Above all — read this entire manual before choosing the parts for your engine or attempting to assemble it. You'll be glad you did.

# HOW TO MODIFY & ASSEMBLE YOUR G.M.C.

## BORING THE BLOCK

Before further cleaning is done to the block, get it bored. Order your pistons ahead of time if you want the best possible fit. Clearance depends on the type of use to be given the engine. Above all, impress on the machinist who is to do the boring that the clearances you are specifying are those that you want. This is a racing engine, even if it is only to be given road use. A great many engines have been ruined by machinists who had to follow the book!

Fit solid-skirt pistons with .005" clearance for mild road use, .007" for hot-road use, or up to .016" for all-out racing. Go ahead and shudder at the last figure, but this is what we use on our own engine. Oil control is not the best, but it sure eliminates the friction and the h. p. jumps 'way up. Knurlizing (a Perfect-Circle Process) can be used to obtain better oil control by removing approximately  $\frac{1}{2}$  the total clearance. In this instance, the block is bored to get the required clearance, and the knurlizing reduces piston clearance for additional oil control without danger of "sticking." Figures are for bottom of piston skirt — extra clearance automatically provided at top by piston design. Fit slipper-skirt pistons for 302 GMC's per manufacturer's recommendations. Excessive clearances are not needed with this type, due to their low-friction design.

## COMPRESSION RATIOS

### VENOLIA PISTON RATIOS

Ratios shown are probably lower than the actual compression ratio which will be obtained from the installation of these pistons. Accurate check can only be made after the engine is assembled. Ratios for either 270H or early head.

|                               |   |       |
|-------------------------------|---|-------|
| Stock block and head..        | = | 8.2:1 |
| Block or head milled .090"    | = | 8.8:1 |
| Block milled .125"            | = | 10:1  |
| Block milled .125", head .090 | = | 12:1  |

### FLAT-TOP PISTON RATIOS

Following have been accurately computed by the cc. glass method. Flat, thinned valves were used, and combustion chambers polished. 1 11/16" exhaust valves — 302 cylinder head, 302 head gasket.

| DISPLACEMENT  | 292" | 296" | 302" | 320" |
|---------------|------|------|------|------|
| Stock chamber | 7.0  | 7.1  | 7.2  | 7.6  |
| .0625" Mill   | 7.5  | 7.6  | 7.7  | 8.1  |
| .125" Mill    | 8.1  | 8.25 | 8.3  | 8.7  |

Special higher ratio pistons are also available for the 302 at extra charge for the special machine work involved.

## PISTON & HEAD COMBINATIONS

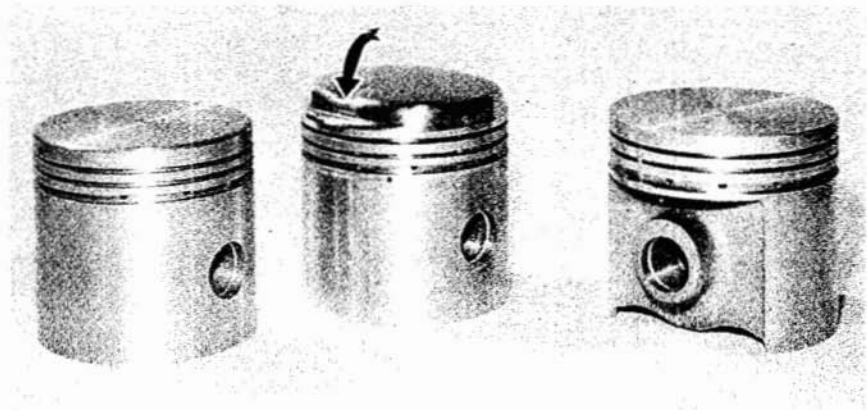

The three currently available pistons for modified GMC's are shown here. At the left is the Fisher piston, designed for use with the Fisher 12-port GMC head, or in a 270 block with a 302 head as illustrated in the drawing below. The McGurk-made Venolia piston in the center is used in more converted GMC's than any other piston. When installing the Venolia piston, the arrow-indicated indentation should be placed toward the sparkplug side of the block. The McGurk slipper-skirt piston at the right is for 302 engines using the 302 head.

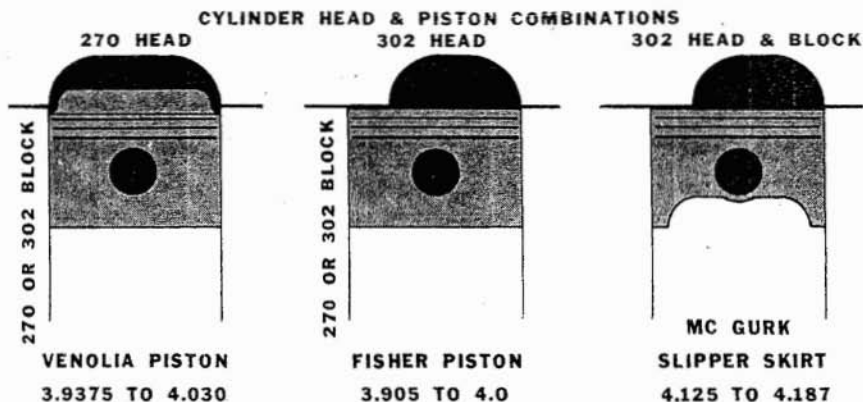

AVAILABLE SIZE RANGE SHOWN FOR EACH PISTON

RECOMMENDED BORES: 270 3-15/16 ————— 302 4-1/8

## LOW-COST ENGINE INSURANCE

Remove pipe plug from existing  $\frac{3}{8}$  NPT hole. Equip with fitting for  $\frac{1}{2}$ " I.D. Neoprene hose. Clean oil from filter enters block at this point.

Saw screwdriver slot in plug made from a  $\frac{9}{16}$  x 18 capscrew. Stake plug in place by punchmarking the threads.

Drill a  $\frac{19}{32}$ " hole, taper ream and tap for  $\frac{3}{8}$  NPT. Install hose fitting for outlet. Oil from pump exits here through  $\frac{1}{2}$ " I.D. Neoprene hose.

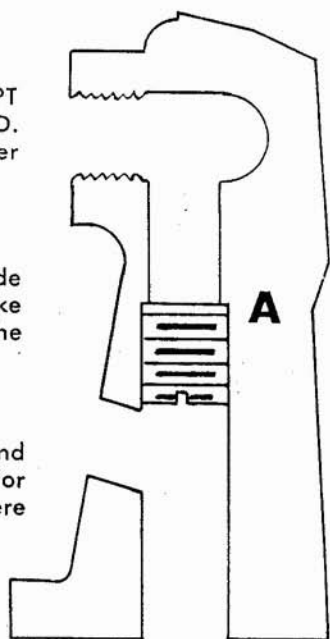

Thread to "A" with  $\frac{9}{16}$  x 18 tap, insert plug.

## FULL-FLO OIL FILTER

Recent tests by the Ford Motor Company, as published in an SAE paper show that the inclusion of a full-flo oil filter (one which filters all oil from the pump before distribution to vital parts) reduced engine wear by the following amounts, as compared to the usual by-pass type filter: Crankshaft wear, 50% less; wrist-pin wear, 66% less; cylinder-wall wear, 19% less; and ring wear, 52% less. Much engine wear starts by sand, cast-iron dust and other foreign matter which cannot be completely removed from an engine when it is first built or overhauled. A by-pass type filter (Fram, A-C, or similar) as installed on many Chevrolets is strictly a compromise measure.

You are spending a large chunk of dough for your GMC — protect it by installing a 1946 Chrysler 6 Full-Flo Oil Filter. This filter is the only one we have found suitable for the purpose. Sold by Chrysler dealers for approximately \$20 as their #1122921. Also buy one line for the filter. This can be cut in half and used for attachment to the  $\frac{1}{2}$ " I.D. inlet and outlet hoses. Use neoprene hoses capable of withstanding at least 150 PSI pressure.



Reworking the oil pan is shown here allows installation of a 270 or 302 GMC in 1949 and later Chevrolet chassis. Modification is necessary to provide clearance for steering mechanism.

## OIL PAN AND OIL PUMP

1937-38 Chevrolets may be GMC-equipped without oil-pan modifications, but the more complex 1949-54 Chevrolet steering arrangement makes modification necessary before the GMC can be installed. Modify pan to provide  $\frac{1}{4}$ " clearance under the front three rods. Fit pan closely around the front of the oil pump and the oil line leading from the pump to block. Pan will remain stock depth from under the pump to the rear of the engine.

If a stationary screen pump is used, cut off the vertical portion of the baffle at front, leaving only a small portion to position the screen.

The float-screen-type pump requires no modification, but must be used with its companion pan.

If in doubt, install the assembled GMC lower end, less pan, in the chassis. Do some careful eyeballing while someone turns the steering wheel from lock-to-lock. The fit is close, but not impossible.

Fill completed pan with water and check carefully for leaks. Hairline cracks usually occur after the pan cools, and these must be repaired. Since the stock GMC dipstick enters the pan ahead of the oil pump, it is necessary to install a new dipstick, using the following Ford parts: Indicator (dipstick) 6750, Tube 6754, Gasket 6753, Boss 6751, 3 Rivets 63359-S. Fill pan with 7 quarts of water and note height in pan. Position boss on pan so its hole will be above this level and opposite the rear-intermediate main cap. Shorten dipstick and insert in pan. Mark full position, remove 1 qt. of water and mark the one-quart low position. These may be file marks.

A typical reworked pan to permit GMC installation in 1949-54 Chevrolets is shown here. Clearance for steering can only be gained by careful reworking of the pan. Bending of the idler arm is to be avoided since this disturbs the basic steering geometry.

Possible GMC oil pan and oil-pump combinations are: Float-type pump, use GMC pan #2191286; stationary-type screen pump, use GMC pan #2135413. Since oil pump body and gears are the same for both pumps, either type can be converted to the other by the substitution of a few parts. To convert float type to stationary: GMC parts 2136438 (cover) 2136439 (cover), and 2136443 (screen). Stationary to floating: GMC parts 2137181 (cover) and 2136008 (float with integral screen).

## ASSEMBLY INSTRUCTIONS

GMC assembly requires no special techniques, but care is needed if the engine is to last. After a complete and thorough block cleaning, install brass freeze plugs at front and rear, stock type on side. Install rear oil-galley plug, cam bearings, and cam plug. Align each cam-bearing hole with its oil-supply hole in the block. Install Chevrolet front motor plate with a well Permatexed gasket. Punch mark fillister-head screws in place. Tap two  $\frac{3}{8}$  x 16 holes in front main cap. Lay upper-half of rear-main oil seal in block, lower half in cap. Roll in place with round object and trim off excess with razor: Install main bearing upper halves in block. Since other half has no holes, *interchange and catastrophe can occur!* Do not align bore main or camshaft bearings. Lay crank (which you have already had balanced) in block and install main caps, torquing bolts to 100 foot pounds. No locks are needed on these bolts. A small amount of Permatex should be placed on the joints where front and rear main caps join block. Place woodruff key in crank and drive on the crank gear. Oil cam bearings and install cam and cam retaining screws. Align timing marks (See page 25). Check rod bearing bores (2.4568 is standard); if the bores are more than .0005" out-of-round, install new rods. Install new wrist-pin bushings as needed, reaming both these bushings and the pistons for an easy thumb-press fit for the pin. Pistons, rods, and wrist pins should be statically balanced. Install pistons on rods, add wrist-pin locks. Align piston and rod assemblies. Install rings, oiling them liberally. Remove rod caps and install pistons in cylinders — using ring compressor. Carefully guide rod down over journal, and install bearings with oil. Torque GMC self-locking rod nuts to 45 ft. lbs. Install block oil-line fitting, oil pump, and oil line. Tighten set screw into oil pump "dimple" until it just bottoms, then back off  $\frac{1}{8}$  turn. **DO NOT OVERTIGHTEN!** Tighten set-screw jam nut. Install oil pan with gasket. Install timing cover, using new seal and gasket. Install woodruff key and drive on the crankshaft pulley. A Chevrolet crank pulley may be used if  $\frac{1}{4}$ " is cut off the shank of the pulley where it butts against the gear. While either the early, "deep" type tappets, or the later "hi" kind may be used, this must be decided before you order pushrods, since the choice determines pushrod length. We prefer the "hi" tappets and short pushrods, since this adds stiffness without weight for more positive valve actuation at high RPM. Install assembled cylinder head with new gasket, and torque head bolts to 90 ft. lbs. Head gasket should be coated on both sides with aluminum paint, then installed while paint is wet. Let set overnight and retorquing to the same figure. Add pushrods and rocker-arm assembly. Back off all tappet-adjusting screws before tightening rocker-stand bolts. Be sure to use the small copper gasket under the front rocker stand or you will not get proper oil supply to the rocker arms. Install oil fitting at front of the main oil galley, and restrictive-type fitting in cylinder head — connect the two with copper tubing, brass fittings. Set tappets: turn engine in clockwise direction as viewed from the front of the engine, watching for No. 6 intake valve to fully open, or that tappet to reach maximum lift position. No. 1 and 6 rod throws are in the same plane and when a valve on No. 6 is fully open, the corresponding intake or exhaust valve for No. 1 will be fully closed and ready for setting the clearance. Follow through the 1-5-3-6-2-4 firing order, watching next for No. 2 intake to fully open and then setting No. 5 intake.

|                             |   |   |   |   |   |   |
|-----------------------------|---|---|---|---|---|---|
| VALVE FULLY OPEN ON NO.     | 6 | 2 | 4 | 1 | 5 | 3 |
| SET CORRESPONDING VALVE FOR | 1 | 5 | 3 | 6 | 2 | 4 |

When setting tappets on a cold engine, allow .002" extra clearance and reset all tappets after engine has run for at least 30 minutes. Tappet clearance adjustments for engines equipped with reground cams should always be made with the engine at rest, since accurate settings cannot be made on an idling engine. See FIRING UP YOUR GMC for distributor installation. Install pushrod cover and gasket, and the fuel pump. Check again that the rear freeze plug and rear oil galley plug are installed, then bolt on the bell housing and flywheel. Four extra holes should be drilled in 228-270 GMC crankshafts to hold the flywheel in place. Tap these for 7/16" SAE Thread, and provide corresponding clearance holes in the 1939 Chevrolet Truck Flywheel you'll be using. (Part No. 838664).

Use hi-strength aircraft-type capscrews, or Chevrolet 7/16 and 3/8 SAE Flywheel capscrews. Use star washers under each cap screw and check that no screw bottoms against the rear main cap or block. Install pilot bearing in recess at rear of crankshaft (GMC ball-bearing type), add ROCKFORD 4038G pressure plate and clutch disc, using a Chevy splined shaft to align the disc as you evenly tighten the nine pressure-plate capscrews. Remove the splined shaft and add the throwout fork and bearing. Install a Chevrolet generator and bracket, 1939-40 Chevy water pump, and a No. 3440 GATES Fanbelt. While a GMC waterpump may be used, this requires GMC pulleys for the crankshaft and generator. If GMC pump and crank pulley are used, it will be necessary to tap the end of the Chevrolet generator armature shaft for 7/16" SAE and use a flatwasher, lockwasher, and cap screw for retaining GMC generator pulley. A GMC fan belt will also be required.

Install the rocker arm cover and gasket, the intake and exhaust manifolds (or headers), and tubing to the Chrysler Full-Flo Oil Filter. Add the Chevrolet thermostat housing, making sure it contains a working 180° thermostat. Install carburetors, linkage, and fuel lines. Install Chevrolet water temperature fitting in rear of GMC head. Mount the coil and install spark plugs. Add wires from coil to distributor, distributor to plugs. Line for oil pressure gage may be installed at 1/8" NPT hole toward rear of main oil galley, or at the GMC fitting at front of main-oil galley.

A Stewart-Warner 360A Oil Pressure Gage may be installed in the car, or some Chevrolets can be fitted with GMC gages by doing only a slight amount of modification to the size of the gage face. If this is done, instrument lighting is simplified. Fire it up!

## DEGREEING-OUT THE CAMSHAFT

Although often overlooked, this step is essential for maximum engine performance. Certain timing is established during camshaft design, but factory-allowed tolerances in camshafts, crankshafts, and timing gear keyways (often inaccurate several degrees each) may "stack-up" to cause large timing variations and consequent ill running. Thus, merely inserting a reground camshaft in your block with the stock timing gears does not insure that the correct timing will be obtained. In fact, the odds are "agin" it.

Either a dial indicator or feeler-gage set is required for the check. A degree wheel may be attached to the crankshaft pulley or flywheel flange and a pointer attached to the block. If a degree wheel is unavailable, use a pointer in conjunction with the ring gear on the flywheel; each tooth is 2.66°.

## DIAL INDICATING METHOD

If a  $\frac{1}{2}$ "-travel dial indicator is available, attach it to the block placing the indicating finger atop No. 1 piston. Rotate crank back and forth until maximum reading is obtained and T.D.C. established. Bend pointer to match  $0^\circ$  or TDC on your degree wheel. Move dial indicator to place its finger in cup of intake tappet or pushrod of No. 1 cylinder. Place crank at compression stroke, TDC for No. 1 cyl. Turning crank back and forth a few degrees. No. 6 cylinder intake and exhaust tappets should be "rocking." Rotate engine in direction it runs (clockwise as viewed from front of engine). When indicator hand moves an amount equal to the timing clearance (NOT RUNNING CLEARANCE) note timing, which should be several degrees before TDC per grinder's tag. Jot this down and continue turning engine until valve opens and closes, watching the dial indicator for timing clearance indication. If you go too far and dial indicator shows no further movement of the tappet, back up the crank until Timing Clearance is again obtained. Note this reading.

## FEELER-GAGE METHOD

Bolt a flat steel piece across No. 1 Cyl. Rotate crank until No. 1 piston crown butts against the piece. Note degree wheel timing. Reverse direction of rotation and repeat. Note timing. Bend pointer midway between the two readings and reset degree wheel so  $0^\circ$  corresponds with the pointer.

Assemble head with valves, springs and retainers installed for No. 1 Cyl. Install head, rocker arms, tappets, and pushrods for this one cylinder. With engine at TDC on compression stroke (see dial-indicator method) set intake tappet clearance with a feeler gage .003" (or your smallest feeler gage) greater than Timing Clearance. Rotate engine in direction opposite to running, if additional clearance can be obtained in  $\frac{1}{2}$  turn of the crank, readjust clearance. Now rotate crank in direction engine runs, leaving the .003" feeler under rocker arm. When this can just be removed, note timing on degree wheel. Continue turning engine until valve opens and closes and gage can be reinserted (.003"). Again note indication on degree wheel.

## HOW TO ADJUST CAM TIMING

Your readings should agree with those on the cam tag. If not, the readings should be in error the same number of degrees on both the opening and closing side. Example: Opening  $6^\circ$  early (cam advanced), closing should be  $6^\circ \pm 1^\circ$ . An error of  $3^\circ$  or more is definitely cause for adjustment . . . not by the cam grinder . . . by you! Since keyway location on crankshaft gears varies considerably, another gear may remedy the error. One crank-gear tooth is equivalent to  $13.33^\circ$ , and often the cam gear can be moved one tooth on the timing gear to get the right timing, or the crank gear can be turned over and a slight variation obtained (requires chamfering front I.D. of bore in gear). Other variations are made by shimming out the camshaft by placing shims behind the bronze retaining plate where it bolts to the block, or shims behind the crank gear.

If the intake timing of this one cylinder is made as near perfect as possible, there is no reason to check the other cylinders. You can check the exhaust timing. If it is off, remedy is by the maker. If your first checks don't agree with the specifications, check again. In all the instances we have seen except one, the difficulty was with the person checking the cam — not in the grind itself.

## FIRING UP YOUR "JIMMY"

With engine completely assembled and tappets set with .002" greater than recommended clearance, proceed as follows:

1. Place 8 qts. oil in crankcase.
2. Check to insure oil-pressure gage installed, oil-filter hoses and fittings secured, rocker-arm oil line installed.
3. Turn oil pump clockwise with extension in electric drill until gage shows pressure.
4. Loosen cylinder-head temperature-gage fitting. While putting water in the engine, watch for appearance of water at fitting before retightening fitting. This eliminates the possibility of air remaining in the head to cause a possible steam pocket and damage to the engine.
5. Turn crankshaft until No. 1 Cylinder is at Top Dead Center on the compression stroke. Turn the crank back and forth several degrees; the intake and exhaust valves on No. 6 Cylinder should "rock." Unless this check is made, you may install the distributor 180° out-of-time.
6. Install the distributor. This is not a simple matter since the distributor drives the oil pump. If not properly installed, you get no oil pressure, with obvious dire results! When you push the distributor into its hole, make sure the distributor-shaft driving tang fully engages with the corresponding slot in the oil pump shaft. Rotate the engine through two full turns while pushing down on the distributor case to insure positive seating in the oil-pump slot. Tighten the distributor clamp enough to prevent removing the distributor, but not enough to prevent your turning it when grasping the case firmly.
7. Set the crank approximately 5° B. T. D. C. as indicated by a ball on the stock flywheel, or by your degree wheel. Insert a cellophane strip (as from a cigarette package) between the ignition breaker points and rotate the distributor counter-clockwise until the cellophane just comes free of the points with a slight pull. Only the distributor housing is rotated, the crank remains stationary. Install rotor and tighten distributor clamp.

**NOTE:** With two-point, single-coil distributors, insert cellophane between points which break last in normal distributor operation; between points for No. 1 cylinder with two-point, dual-coil-type distributors.

8. Install distributor cap and insert wire for No. 1 Cyl. in the cap connector opposite rotor position. Wire stock cap in clockwise direction: 1 - 5 - 3 - 6 - 2 - 4. Install condenser-to-coil and switch-to-coil primary leads.
9. If engine is new or just rebuilt, use two batteries in series to supply 12 volts to the starter. Center tap at 6 volts for coil. This causes no apparent harm to the starter as long as it is used sensibly.
10. With ignition switch OFF, crank engine with starter until oil pressure shows at gage.
11. Flip switch and start your "Jimmy!"

**OIL NOTE:** Converted GMC engines require a fairly heavy oil for long life. SAE 40 is recommended for conservative road jobs; SAE 50 VALVOLINE for hot-road jobs and all-out competition. Additives are not needed. If lighter oil is used for cold weather, it is important that it be changed to a heavier grade whenever competition is undertaken.

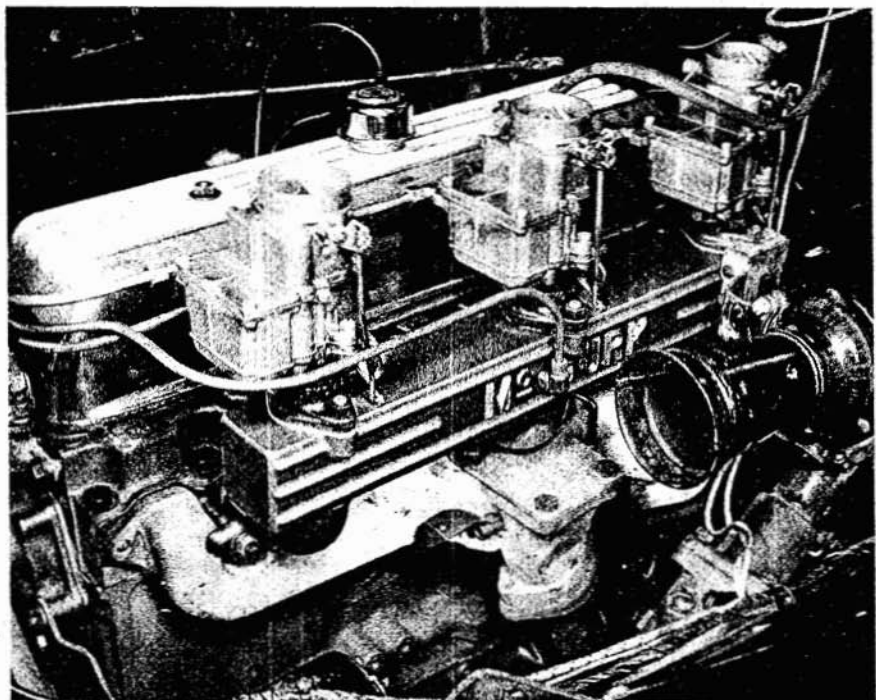

## THE 261 CHEVROLET

First introduced in 1954, Chevrolet's 261-cubic-inch truck engine is a good bet for Chevy owners who don't want to build a GMC. Its installation and construction costs are less than for a GMC, and more of the stock Chevy parts can be used with the 261. Owners of 1953-54, and 1955's can use their present full-pressure crankshaft, connecting rods, cylinder heads, and any other speed equipment they may already have. In fact, owners of these models will have about everything they need except a block and perhaps a camshaft. Their other stock parts fit perfectly. Any intake manifold, stock or special, from a 50 or later Power Glide, or any 53-54 can be used with a 261. 1942 and later flywheels have the same bolt pattern.

Recent tests by McGurk Engineering indicated that the engine, although factory rated at 135, produces 110 h.p. in stock form, and can be boosted to 200 h.p. on gasoline when equipped as follows: Corvette exhaust manifold, three-carburetor down-draft manifold, 3-7/8" pistons, tubular pushrods ported, 235 cylinder head milled .030", lightened valves, dual valve springs, competition retainers, dual-coil ignition, and a full-race cam. When this combination inhaled through only two carbs, 180 h.p. resulted. Replacing the full-race with a 3/4 type cam dropped the output to 175 with the triple carbs, 165 with the duals.

While the horsepower available from this rugged engine is certainly not equal to that provided by a GMC, its low cost and ease of installation — no radiator moving is required with a 261, nor pan chopping for installation in '49 and later—will undoubtedly appeal to many Chevrolet owners already having some of the necessary equipment.

*late passenger car engine head* 36

## CHEVY-GMC CONVERSIONS

A GMC-equipped Chevrolet may be likened to the proverbial wolf-in-sheep's-clothing . . . innocent looking but fierce! The easy-to-make installation requires no special tools or know-how provided you understand the basic modifications which are required.

The four most important points are lengthening the front motor-mount position by means of extensions similar to those sketched below, a new exhaust system, lengthened throttle and fuel line connections, and moving the radiator forward.

Care must be used when installing the exhaust system as clearances for clutch, brake, gearshift, and steering linkages must be maintained.

Use Chevrolet front motor mounts instead of the usual stock Chevy rear motor mounts. This requires enlarging the mount brackets for the 7/16" bolts. The heavier mounts are required for the greater torque produced by the GMC tends to rip the stock mounts apart in very short time.

**1937-39 MODELS:** Remove grill, radiator and shell assembly, bracing rods, Chevrolet engine and transmission. Add extension motor mounts at front. Bolt transmission to GMC engine and install the combination in the chassis. Hook up exhaust system, etc., move radiator forward into shell 1 1/2" by modifying sheet metal to clear. Install radiator, and bodywork.

**1940-48 MODELS:** Remove entire front-end sheet-metal assembly. Remove Chevrolet engine, preferably with the transmission. Add extensions to motor mounts, install the GMC. Move radiator forward 1 1/2" by modifying bottom gravel shield to clear. On 42 and later models, the cowl by the top of the radiator must also be cut for clearance. Reinstall radiator and bodywork.

**1949-52 MODELS:** Remove hood, grill, radiator and gravel shields. Radiator mounting-bracket brace is retained by spot welds. Remove intact with careful chisel work. Remove Chevrolet engine and the transmission. Install motor-mount extensions. GMC pan must be modified per instructions in engine assembly section. Install GMC. Remove radiator-mounting frame from radiator, reverse it and solder in position. This moves radiator forward required amount. Modify gravel shields and hood brace above radiator for clearance. Install radiator, radiator frame brace behind radiator, and bodywork.

**1953-54 MODELS:** Follow same pattern as for 1949-52's, except holes for earlier style front motor mounts must be added in the crossmember. Install these in approximate center of member and add extensions for attachment to Chevy front motor plate.

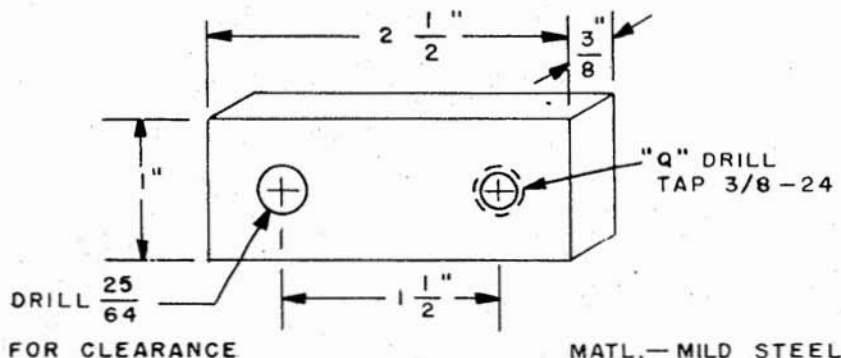



## GMC - FORD CONVERSIONS

Undefeated thru the 1952 Drag-Race Season, the FISHER-WINFIELD coupe was retired from competition at that time in favor of constructing a lighter model. FISHER 12-Port powered, its top time for the standing-quarter mile is 115 mph. Possessing exceptional low-speed torque and ability to "get out of the chute" its elapsed time over the quarter mile was less than required by cars turning speeds up to five miles per hour faster.

While converting a Ford chassis to use the GMC engine is not quite as "cut and dried" as a similar installation in a Chevrolet, the installation is well worth the small amount of trouble which is involved. Since many fellows are eager to secure the excellently suited Lincoln-Zephyr gear ratios for use with their GMC's, such an installation allows gears to be no more of a problem than purchasing them and stuffing them into the Ford transmission. A Cyclone adapter bell housing makes the whole deal "duck soup."

Since the GMC engine is a bit longer than the average space available in a Ford engine compartment, it is necessary to shorten the driveshaft, move the transmission and rear transmission mounts rearward, and notch into the firewall to clear the rear of the engine. There is no problem with steering-mechanism interference, and the oil pan can be run "as is." Allow 35 inches (measured from the transmission flange) for the GMC. Remember that the farther back you can move the engine, the better your weight distribution will be and the better traction that will be obtained from a stop. Moving the engine back also improves the general handling characteristics of the automobile, since most cars today are definitely nose heavy.

The Ford clutch-actuating mechanism is used with the Cyclone housing, but it will have to be moved rearward to match up with the migration of the transmission in that direction. A Ford clutch is used, together with a 1939-Chevrolet-truck flywheel which has been drilled for the Ford clutch. A pilot-bearing adapter is supplied with the adapter housing to allow use of the Ford bearing.

Front-motor-mount installation is a simple task involving a tube welded from one frame rail to the other. Its height should be such that the engine's crankshaft centerline and that of the transmission meet the drive shaft at as near a straight line as possible, assuming the car is normally loaded. Power used to overcome friction created by excessive U-joint angles doesn't do you any good at the rear wheels.

For simplicity of making the conversion, change the Ford electrical system to a complete GM negative-ground type, using a Chevrolet or GMC generator and starter, in conjunction with the matching Delco-Remy voltage regulator.

Most fellows block off the upper-right and lower-left radiator inlets to allow use with the GMC cooling system.

# FUEL AND HOW TO USE IT

While many of you who get this manual will never use any fuels other than those gasolines obtainable locally at your service station or airport, there are others who will want to obtain maximum power for competition by using special fuels. Methanol ("alky") is most common of the special fuels used today. This fuel can be blended with more potent additives, such as nitromethane, to further improve horsepower.

Except for single-carburetor competition machines, the use of the stock fuel system is not recommended. Tests may even show that it will not prove adequate in some of these installations. The stock fuel pump must be replaced with a unit such as the CARTER M 751 or M 779. Each of these has a neoprene diaphragm, essential for use with methanol-base fuels.

For more stringent racing applications we can supply pumps to meet the most rigid requirements. Both electrical and mechanical types are available. While electric types are not required for the average installation, some builders of sports cars feel that they are needed for long-distance events where the engine is held at full throttle for long periods. Our recommendation in such an instance would be the purchase of a pair of BENDIX Eclipse Fuel Pumps with the optional stainless-steel plungers.

Regular drag racing requires the use of a standard, pressure-type system. Consisting of a hand-operated air pump, air-tight fuel tank, and necessary lines, shutoff valve and distribution equipment, these systems usually incorporate a fuel-pressure gage operating directly off of the line. A pressure-type system is considered essential for methanol since the very use of this fuel requires a system capable of transmitting from two to four times as much liquid as the typical gasoline-supply system. The stock system will not get the job done with a multiple-carburetor engine running methanol. Don't even bother to try it as there is a good chance of starving your engine so badly that it will "burn up" from a lean mixture.

## ALCOHOL CARBURETOR MODIFICATIONS

Complete details for modifying the STROMBERG EE-22 for alcohol burning, single-carburetor competition engines are given elsewhere in the manual. However, a few fellows will be interested in converting Ford V-8 carburetors for competition use. These are easy to convert, quite cheap to obtain, and are used on many all-out record-holding cars.

The STROMBERG "97" is perhaps the most popular of all for these conversions. Details for its conversion are as follows:

Drill dump tubes to .116" or make up special discharge nozzles with an inside diameter of .187" if large percentages of nitro are to be used. Drill accelerating-well jet to .070" with a No. 50. Main jets should be augered out to a diameter of .086" with a #44 drill. Chop off the idle tubes just below the shoulder and open them up to .040" with a #60 drill. The needle seats should be drilled out to .125" for straight alcohol, or to .140" for mixtures with nitro.

As you can see, there are no real "speed secrets" involved in making alcohol carburetors. About the only other changes required are large-diameter tube connections to the needle seats. Anyone with a set of number drills and a STROMBERG jet wrench can do the job.

Neoprene tubing with  $\frac{3}{8}$ -inch inside diameter is usually used to carry fuel from a fuel-distribution block to the carburetors. Fuel is led from the tank through a shutoff valve to the distribution block through  $\frac{1}{2}$ "-I.D. neoprene hose, or transparent plastic garden hose.

## WHY USE SPECIAL FUELS?

Methanol provides approximately 20% more horsepower than gasoline, even though its heat energy content, i.e., BTU/lb. is less. It makes up for this lower energy by a lower latent heat of evaporation which allows more fuel to be crammed into your cylinders and at lower temperatures, thus improving your engine's efficiency.

Nitromethane in amounts even greater than 50% is occasionally mixed with methanol for use in short-distance races as in qualifying at the track or in drag racing. It is sometimes used in smaller percentages for track racing where the engine can be kept cool. In the absence of special coolants, 25% nitro is considered about maximum for use with a stock-head GMC running at the drags, 10% for track or lakes engines. While we know for certain that these percentages are exceeded greatly, only a relatively few have been able to do it and "get away with it." My personal experience has been that the fellow who uses nitro most efficiently will first learn how to make his engine run on methanol. *Nitro is not for the novice.*

Nitro is usually mixed with methanol by mixing the two in a five-gallon can by vigorous shaking. The need for care cannot be expressed too strongly. Perhaps the best way to remember that what you are working with is dangerous is to consider constantly that nitromethane is often used as a rocket propellant.

## TECHNIQUES

When using special fuels, it is essential to eliminate all of the hot spots from the combustion chamber, since these can cause engine-wrecking detonation. Detonation can be happening and not be heard in a competition engine. It is often masked by exhaust and other noises. A careful check should even be made to see that no head or spark-plug threads are exposed to the combustion process. If spark-plug threads protrude into the chamber, a special gasket must be made for each plug to get the proper spacing. **NEVER USE MORE THAN ONE PLUG GASKET!** To do so disturbs the heat-transfer characteristics of the plug, making it impossible to get meaningful plug readings.



Bolting the flywheel to the GMC crank provides a means of holding the two for drilling holes for four extra flywheel-retaining capscrews.

# HOW TO SELECT GEAR RATIOS

We receive hundreds of letters on gear-ratio selection. Most of them boil down to the simple fact that the writers are after two or three incompatible performance factors which are unachievable, no matter what gear-ratio and transmission combination is chosen. There is no one "magic" gear ratio which will provide best top speed, utmost acceleration, and the ultimate in gasoline mileage. While these factors don't walk the same paths, some effective compromises can be made, as is proved by today's fine stock automobiles.

## REAR-END RATIOS

Mr. A. S. E. (Average Speed Enthusiast) installs a few items of equipment in his engine and then rushes to purchase the highest-available gear ratio set for his differential, thinking to increase top speed and decrease engine friction at one blow. Take our word for it — it is an awful shock to learn that much of the additional performance provided by special equipment can be bled off through improper gear selection.

**NOTE:** Low numerical values are considered "high" ratios, i.e., 3.55:1 is a higher ratio, but lower numerical value than 4.11:1.

While 4.11:1 gears are removed by the hundreds to make way for higher ratios, these oft-unwanted cogs are still a man's best friend for drag racing and town driving where maximum acceleration from a standstill up to one-quarter mile is desired. This holds true for 1900-pound competition cars up to heavy sedans, which could actually use a lower gear ratio to advantage if a better choice of transmission was available. Our 1932 Ford Coupe with GMC engine weighs 1963 pounds, yet uses 4.11 gears for dragging. Why? Higher gears gave poor out-of-the-chute acceleration, and lower speeds at the end of the quarter mile. Lower gears provided no advantage, since traction could not then be obtained, even using second gear for starting, as is customary practice.

If YOUR car burns off too much rubber in low-gear starts, use second gear to start, and perhaps reduce the size of your rear tires to get a better ratio compromise. For best acceleration, even second-gear starts with a really hot GMC should just break the tires loose from dry-asphalt pavement.

Remember that even the hottest engine can be made to feel like a lawnmower engine by choosing the wrong gear ratio.

Ring and pinion-gear combinations are shown in the accompanying table. 1940 and later ring and pinion sets may be installed in 1937-39 rear ends by adding a late drive-shaft splined collar to the earlier drive shaft to allow fitting to the pinion-gear spline.

## CHEVROLET GEAR RATIOS

| MODEL   | PART NO. | STAMPED         | NO. TEETH | RATIO  |
|---------|----------|-----------------|-----------|--------|
| 1937-39 | 602443   | 593002-01       | 38-9      | 4.22:1 |
| 1937-39 | 602440   | 595022-21       | 41-11     | 3.73:1 |
| 1940-52 | 604397   | 595022-3652285  | 41-11     | 3.73:1 |
| 1940-52 | 604398   | 3652178-79      | 37-9      | 4.11:1 |
| 1950-52 | 3694806  | 3691464-65      | 39-11     | 3.55:1 |
| 1953-54 | 3701929  | 3697720-21      | 37-10     | 3.70:1 |
| 1953-54 | 3705262  | 3691464-3704417 | 39-11     | 3.55:1 |

A 3.73 or 3.55:1 rear-end ratio is definitely recommended for those GMC-Chevy owners who don't necessarily need maximum acceleration, but want either all-out top speed, or fast and economical cruising.

If you read any of the hotrod magazines, you are undoubtedly aware that quick-change rear ends are a fairly common item. Unfortunately, none is available for Chevrolet rear ends. Reasonably quick ratio changes may be made by keeping a carrier set up with bearings and ring gear, and a complete pinon, drive-shaft, and double-row bearing assembly with the other gear you use for competition. Changes may then be made from the differential housing by removing the carrier and ring gear, then using a prybar (with approximately 2 inches bent at a right angle to the rest of the bar) to remove the pinon, bearing, and driveshaft without breaking the U-Joint. It is assumed that the novice will consult a Chevrolet Shop Manual before attempting the job.

The only type of quick change rear ends now available are the center-section type for Ford rear ends. Those desiring all-out machines will probably be better off making their GMC installation in a Ford chassis, since this eliminates much time-consuming adaptation. Several Chevs in the Southern California area have been equipped with Ford rear ends by adapting a cross-type spring and Ford cross member to the chassis.

## TRANSMISSIONS

It may come as a blow to some dyed-in-the-wool Chevrolet fans to learn that stock Chevrolet transmissions provide ratios which are "for the birds" as regards racing of any kind, except flat-out high-gear contests. Many GMC-equipped Chevs lose drag races to competitors with lower-powered engines because the other cars have a better gear-ratio choice. Transmission modifications can make a GMC-Chevy an even more outstanding performer. A GMC turning 5000 in low gear loses 2000 RPM on the shift to second, and repeats this performance on the high-gear change. Since 3000 RPM is just below the point at which the horsepower curve starts its sharp upward rise, a lot of ground is lost until the engine starts to "put out" again.

If you apply GMC horsepower to your stock Chevrolet transmission, it is essential to install a needle-bearing cluster gear, which will fit 1940-53 Chevrolet transmissions. The following parts are required:

1 - countershaft 591213, 7/8" x 7-7/32" (no flat spots)

1 - countershaft gear 591191 (cluster gear)

50 - rollers 435847 and 2 - washers 591212

1937-39 Chevrolet transmissions may be similarly equipped, but require (in addition to above listed parts) a special short mainshaft, and a complete set of 1940 or later gears. Don't buy any late gears until you have obtained the special shaft, as they are only available in limited quantity.

Obviously, many Ford boxes have been bolted onto GMC engines, but they don't have adequate strength to cope with the GMC's brute torque—as proved by the many which have been scattered under application of full power. The problem of installing a Ford box doesn't end with buying an adapter—it just begins. The problem of fitting this trans in a Chevy chassis assumes major proportions when the drive-shaft, linkage-adaptation, and clutch-flywheel problems are encountered. The writer also tried the Cadillac

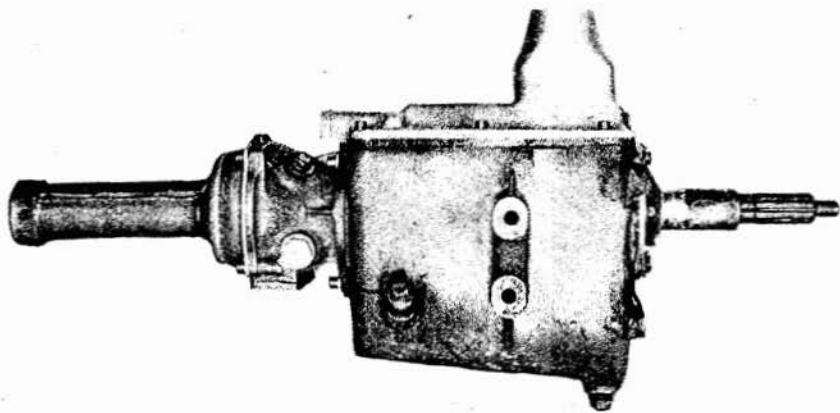

box, a unit quite rugged, but far more expensive to adapt than one pictured above and described below.

If you are really serious about drag racing to win trophies, replace your Chevrolet transmission with a Packard, either floor- or column-shift type. The Packard transmission adaptation is so simple that it almost makes one weep to think of the many years Chevy fans stumbled by these low-cost jewels rusting in the junkyards. A special spacer compensates for the 3/8" longer clutch shaft (same spline as Chevrolet) and also matches the larger bearing-retainer and mounting holes of the Packard to the stock-Chevy bell housing. Your Chevrolet throwout-bearing and clutch assembly can be used without modification, or if you are really serious about racing, the stock or Rockford clutch you are now using should be replaced with a Borg & Beck clutch similar to the Buick Century unit. The FISHER adapter/spacer plate is available separately, or in kit form with modified U-joint (Packard front half, Chevrolet rear) and rear-transmission support assembly. The support is a modified No. 590792 ('36 Chev. Master). Its flange must be turned smooth, new holes drilled and tapped in the transmission and support flange, and the support's bearing bore enlarged to fit over the rear bearing and snap ring. The only problem which arises is one of drive-shaft and torque-tube lengths. Where the stock shaft is too long, both can be cut; if additional drive-shaft length is required, use the Chevrolet "Suburban" torque tube and drive shaft. Due to the U-Joint adaptation, a later drive shaft must be used in 1937-39 Chevs when adapting the Packard transmission. This allows use of the later Chevrolet gears (through 1954), or if you don't wish to change the gears you already have, weld the internally splined collar from your 1937-39 drive shaft onto the later shaft. Complete details for the modification are supplied with the spacer/adaptor plate. A stick-shift Packard box is shown above, adapted for installation in a Chevrolet. The spacer plate is not illustrated.

The Packard transmission you'll use depends on whether you want a 1935-38 floor-shift type (Casting No. 302512-2), or a 1938-47 column-shift type (Casting No. 333571). Either has the same ratios (2.43 low which is 20% higher than Chevrolet, and 1.53 second), but the later unit has a constant-mesh low gear which is somewhat more silent in operation than the earlier type. Second-gear ratio is just between a 25- and 26-tooth Zephyr. If you choose the column-shift type, be sure to check the external blocker teeth which engage with the sliding low and reverse gear. A 1949 or later Chevrolet shifting-linkage assembly must be used with the column-shift type.

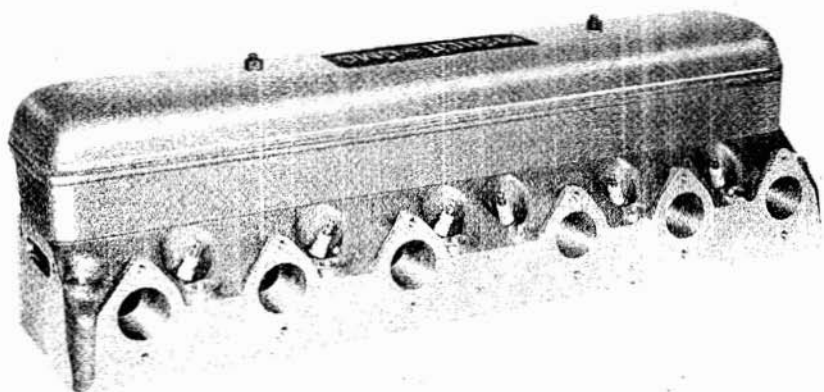

## FISHER 12-PORT GMC HEAD

Originally designed by Wayne F. Horning, this head is now being manufactured of 356-T6 aluminum alloy, and weighs only 32 pounds. Design modifications which have been made allow us to sell these heads at a price less than required for any other special GMC head, even including the billet cam which is required by the straight-through porting arrangement and spark-plug location. Users of it report that this head far outclasses engines otherwise equipped.

### COMBUSTION CHAMBERS

The only available special GMC head with combustion chambers, the FISHER chambers provide unrestricted breathing regardless of bore size. Aluminum provides maximum heat rejection into the cooling water to allow use of large quantities of nitro methane.

### VALVES

Lightened 1-7/8" intake, and 1-5/8" exhaust valves seat on cast-iron rings positively positioned at time head is poured. Valves are amply sized to meet the breathing requirements of the biggest 270 and 302 engines.

### GUIDES

New, one-piece precision-machined guides are designed to restrict their movements, an exclusive feature in this head.

Round combustion chambers provide unrestricted breathing regardless of bore size. Cast-iron valve seats positioned at time of casting CANNOT COME OUT!

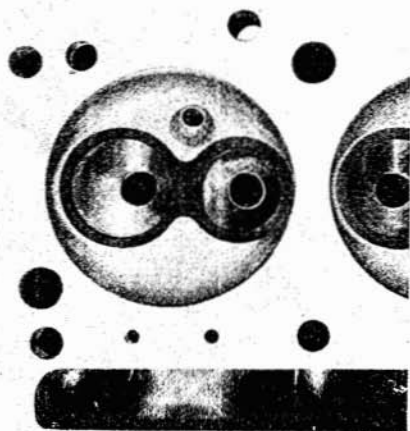

## ROCKER ARMS

A highly polished two-piece rocker-arm cover allows tappet adjustments to be made without oil spilling over the engine.

## SPARK PLUGS

The cartridge-fire principle is used, with the flame entering the combustion chamber near the exhaust valve as proven best in engineering practice. J-2 or J-3 Champion spark plugs seat perfectly against "end gaskets" which eliminate all possibility of detonation occurring from exposed spark-plug threads. Plug location allows normal rates of spark advance to be used, thus improving power.

## PORTS

Large, straight-through intake ports with easily radiused turns provide unrestricted flow of the mixture without impeding its velocity. Exhaust ports provide positive scavenging.

## BILLET CAMSHAFT

A stock GMC cam cannot be reground and used with this head. However, several cam manufacturers are grinding cams for this head at only slightly more cost than that required for a new stock GMC camshaft with a regrind. Road and racing grinds are available. The cams are equipped with both distributor-drive gear, and fuel-pump eccentric cam.

## PERFORMANCE

Over one horsepower per cubic inch with methanol-based fuels, or 0.8 to 0.9 h.p./cu. in. with gasoline, depending on rest of equipment used. Both carburetion and fuel-injection systems are available for the head.

# IGNITION

Recognizing a long-felt need in this particular portion of GMC (and Chevrolet) engine building, California Bill is now manufacturing kits to convert your present distributor for two-coil, two-point operation at a fraction of the cost of previously available two-coil distributors or magnetos. We are also making complete dual-coil distributors at very reasonable prices.

Although other types of ignition conversions are available (using single coils) we felt that many of our customers really wanted more positive assurance that their ignition system would perform perfectly, without missing when high RPM was wanted.

## THE FISHER DUAL-COIL CONVERSION KIT

The kit consists of a complete set of parts and instructions for converting your Chevrolet or GMC distributor for dual-coil operation. It includes: dual-point plate; two sets of high-speed, heavy-duty ignition points; two condensers; three-lobe cam; rotor; special cap and cap adapter; and necessary wire and hardware. The kits may be purchased with BOSCH Condensers *at slight additional charge*. Anyone can install one of these kits, as it is very simple to do.

## THE FISHER DUAL-COIL DISTRIBUTOR

Using the same kit on a brand-new Chevrolet distributor, we mount the necessary parts, and test the completed unit before shipment. We recommend that the complete unit be purchased with a pair of matched coils.

**NOTE:** Distributor-cap numbers indicate cylinders to which the spark-plug wires should be connected.

## MALLORY TWO-POINT KIT AND BEST COIL

Many of our customers find that this combination works out to their satisfaction for conservative road job use. It produces more voltage than the stock ignition, is easy to install, and provides long life. The kits will also perform satisfactorily with a stock coil.

## SCINTILLA VERTEX MAGNETO

Since the VERTEX is the only presently available magneto suitable for use with converted GMC (and Chev.) engines, it is only fair to mention it here. These units supply hot sparks at any RPM, and completely eliminate the need for a battery-powered ignition. Various advance characteristics are available on order. The magneto is usually used for track and drag-race cars. Such units should always be installed with a positive-action toggle switch for grounding the magneto and stopping the engine. *Do not use a push-button type switch to ground a magneto.*

**NOTE:** Magneto-cap numbers indicate magneto firing order, not the engine firing order or the cylinders to which the wires should be lead.

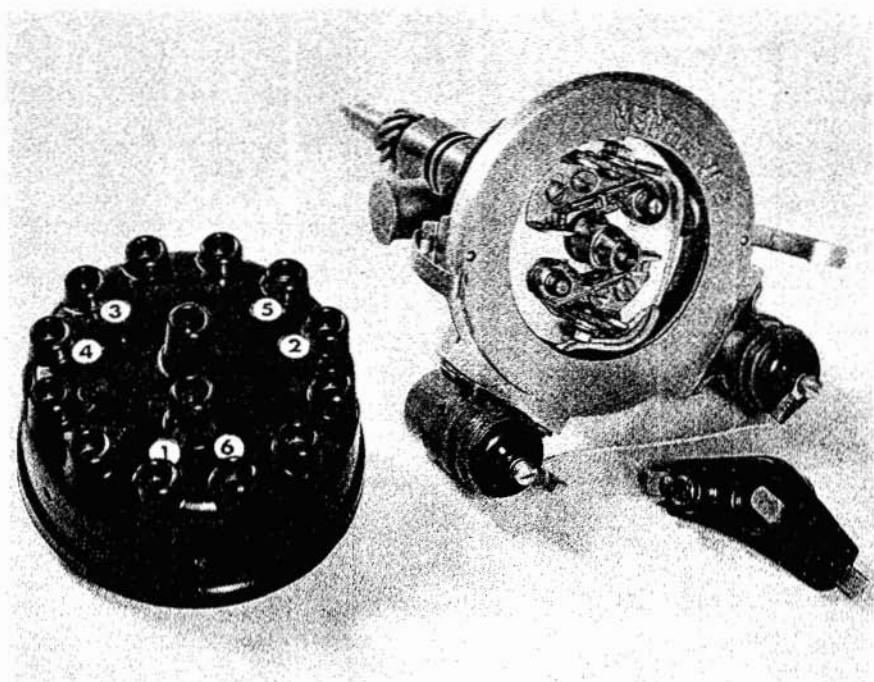
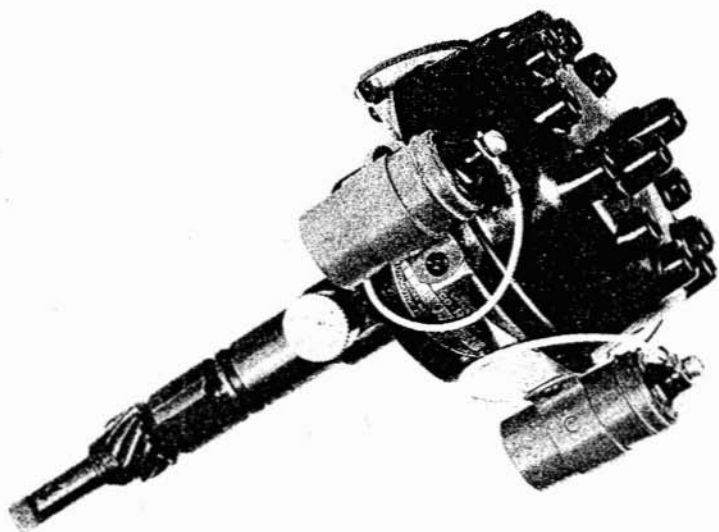

The two above photos show the Fisher dual-coil conversion kit parts and a completely converted distributor after kit installation. All necessary parts and complete instructions are included in these reasonably priced kits.

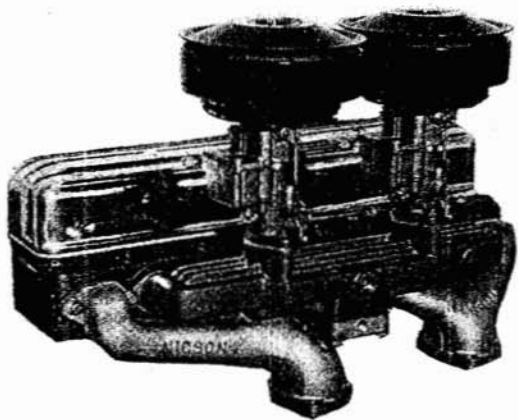

Oil bath air cleaners on a Nicson dual-carburetor intake manifold. Box-like attachment uses engine-water heat to provide smooth operation and positive fuel vaporization, even though headers are installed. Nicson headers and cast-aluminum rocker-arm cover are also shown.

## AIR CLEANERS

Many would-be hotrodders operate their engines without air cleaners. This makes their engines noisier, thus more racy sounding to their untrained ears. Definite harm through rapidly increased wear is the inevitable result of operating any engine without proper cleaning devices. Contrary to popular opinion, efficient air cleaners cause no loss of horsepower.

Drag race, track, and "lakes" engines are operated without cleaners since alcohol-burning engines are frequently troubled with float-valve sticking and it is necessary to check for this condition by looking into the carburetor throats when the fuel valve is turned on. Attempting to start a flooded engine can cause serious internal damage such as collapsed cylinder walls and pistons, bent connecting rods, etc.

While the presently popular chrome-bonnet-type air cleaners are attractive, their copper-mesh construction offers no real protection against the entrance of dust and grit. In many cases, their design is such that carburetor air flow is restricted enough to cause serious horsepower losses. This has been proved on chassis dynamometers. So, remember that the best looking air cleaners are often at the same time least efficient.

Where dual carburetors are used on a road engine, two oil-bath air cleaners should be installed to provide the best protection against dirt. These efficient air cleaners are also good silencers and will fit all GMC dual manifolds now on the market.

Chevrolet air cleaner, Part No. 1529667 can be installed for an efficient cleaner-silencer. These can usually be picked up at junk yards for no more than 50 cents each, as they were used on almost all Chevys from 1937-48. Cleaning and painting requires only a little time, and we have found they have better silencing characteristics than any other air cleaner.

For triple-carburetor installations, we suggest Chevrolet (and A-C) Part No. 1529264. These also work nicely on dual installations and they can be chromium plated for added appearance.

Al Surabian of Dinuba, California owns and races this FISHER head-equipped GMC-powered 1948 Chevrolet which has been timed at 103.25 mph at the quarter-mile drag races. During 1953, the fully upholstered, unguitted 3300 pound coupe was run at 16 drags, placing first 15 times - - at speeds consistently over 100 mph. The one second place was due to clutch trouble, since eliminated by installing a  $\frac{3}{4}$ " mild steel plate in the ROCKFORD Clutch assembly. An aluminum flywheel is used with a steel facing to eliminate excessive wear. A 4.11:1 gear is used with a Packard transmission, 7.60x15 Slick Track Tires in the rear for traction.

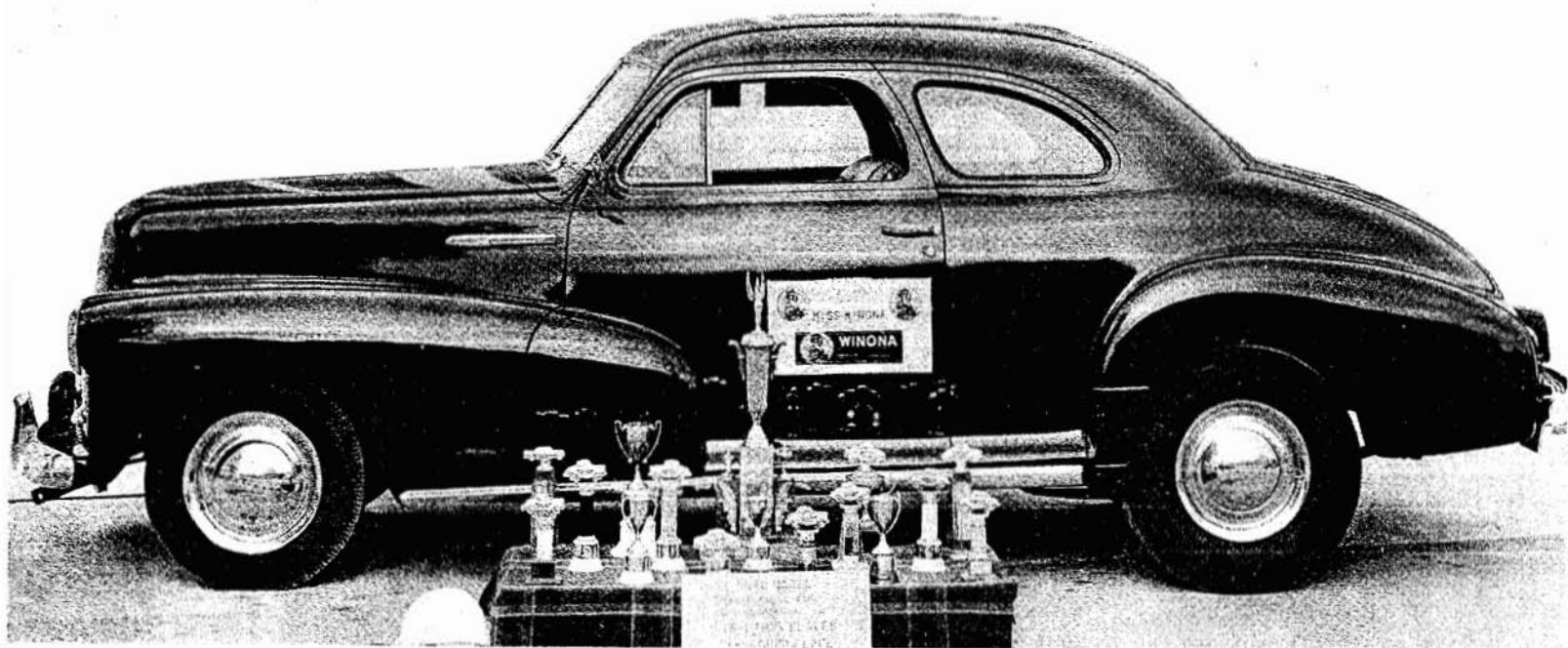

COPYRIGHTED

February 1, 1955

by the author and publisher

**FRED W. FISHER**

Permission to reproduce any portion of  
this manual must be obtained before use